

Key: 9169

Town of Bourne - Fiscal Year 2024

12/18/2023 6:02 pm SEQ #: 9.378

LEGALS LAND

CURRENT OWNER		PARCEL ID		LOCATION	
JOHNSON ELIZABETH J 66 BEAVER POND RD LINCOLN, MA 01773		43.1-166-0		150 BELLAVISTA DR	
TRANSFER HISTORY		DOS	T	SALE PRICE	BK-PG (Cert)
JOHNSON ELIZABETH J BLOUNT RITA M		12/11/2015 04/21/1971	QS XX	365,000 (208227) 408-018	

CLASS	CLASS%	DESCRIPTION			BN ID	BN	CARD	
1010	100	SINGLE FAMILY				1	1 of 1	
PMT NO	PMT DT	TY	DESC	AMOUNT	INSP	BY	1st	%
15416	06/05/2015	3	ALT/RENO	11,850	04/27/2018		100	100

CD	T	AC/SF/UN	Nbhd	Infl1	N Index	ADJ BASE	SAF	Topo	Lpi	VC	CREDIT AMT	ADJ VALUE	
100	S	14,860	11	1.00	100	1.00	424,260	2.20	A	1.00	R09	1.80	318,500

TOTAL	14,854 SF	ZONING	1	FRNT	0	ASSESSED	CURRENT	PREVIOUS
Nbhd	POC	NOTE	LAND	318,500	258,400			
Infl1	AVG		BUILDING	336,800	290,700			
N_Index	AVG		DETACHED	0	0			
			OTHER	0	0			
			TOTAL	655,300	549,100			

DETACHED

TY	QUAL	COND	DIM/NOTE	YB	UNITS	ADJ PRICE	RCNLD

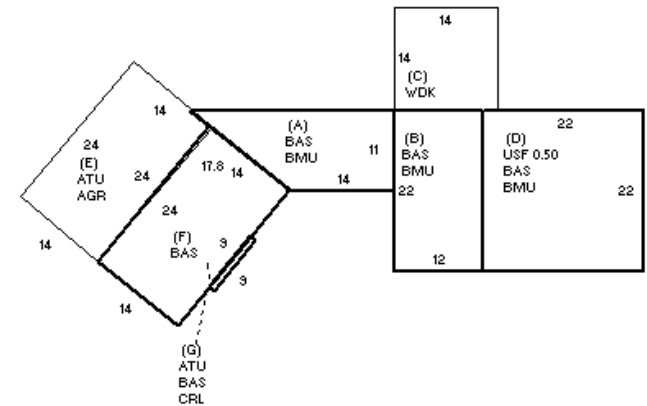

BUILDING

BUILDING	CD	ADJ	DESC	MEASURE	8/17/2023	SL
MODEL	1		RESIDENTIAL	LIST	8/17/2023	EST
STYLE	4	1.05	CAPE [100%]	REVIEW	10/11/2023	TL
QUALITY	A	1.00	AVERAGE [100%]			
FRAME	1	1.00	WOOD FRAME [100%]			

BLDG COMMENTS

G

YEAR BLT	1971	SIZE ADJ	1.010
NET AREA	1,566	DETAIL ADJ	1.000
\$NLA(RCN)	\$283	OVERALL	1.120
CAPACITY		UNITS	ADJ
STORIES	1.5	1.00	
ROOMS	6	1.00	
BEDROOMS	2	1.00	
BATHROOMS	2	1.00	
FIXTURES	8	1.00	
GARAGE CAPACITY	1	1.00	
% BSMT FINISH	0	1.00	
# OF HALF BATHS	0	1.00	
# OF UNITS	1	1.00	

ELEMENT	CD	DESCRIPTION	ADJ	S	BAT	T	DESCRIPTION	UNITS	YB	ADJ PRICE	RCN
FOUNDATION	4	FLR/WALL(FULL)	1.00	+	BMU	N	BSMT UNFINISHED	979		41.25	40,383
EXT COVER	1	WOOD SHINGLE	1.02	C	WDK	N	WOOD DECK	196		39.56	7,754
ROOF SHAPE	1	GABLE	1.00	D	USF	L	UPPER STORY FIN	242	1971	124.47	30,122
ROOF COVER	1	ASPH/COMP SHIN	1.00	E	AGR	N	ATT GARAGE	336		78.96	26,529
FLOOR COVER	1	HARDWOOD	1.02	E	ATU	N	ATTIC UNF	336		47.81	16,064
INT. FINISH	2	DRYWALL	1.00	+	BAS	L	BASE AREA	1,324	1971	212.65	281,542
HEATING/COOLING	9	WARM-COOL AIR	1.03	G	CRL	N	BSMT CRAWL	336		38.75	13,021
FUEL SOURCE	2	GAS	1.00	G	ATU	N	ATTIC UNF	336		47.81	16,064
USE	0		1.00	FIX	O		XTRA FIXTURES	3		2,409.07	7,227
				MST	O		MAS/METAL STACK	1		4,514.60	4,515

TOTAL RCN	443,221
CONDITION ELEM	CD
EXTERIOR	A
INTERIOR	A
KITCHEN	A
BATHS	A
HEAT	A
ELECT	A
EFF.YR/AGE	1995 / 27
COND	24 24 %
FUNC	0
ECON	0
DEPR	24 % GD 76
RCNLD	\$336,800