

Key: 93

Town of Bourne - Fiscal Year 2024

12/18/2023 6:02 pm SEQ #: 91

LEGALS

CURRENT OWNER				PARCEL ID				LOCATION			
DORMAN GARRIE WOODWORTH TR GARRIE WOODWORTH DORMAN TR 5 JONES LN SAGAMORE BEACH, MA 02562				2.0-17-0				5 JONES LN			
TRANSFER HISTORY				DOS	T	SALE PRICE	BK-PG (Cert)				
DORMAN GARRIE WOODWORTH T				06/03/2014	F	100	28181-181				
DORMAN GARRIE W &				06/01/1999	QS	250,000	12308-202				
BUTLER KENNETH A &				12/19/1997	QS	58,000	11124-265				

CLASS	CLASS%	DESCRIPTION			BN ID	BN	CARD	
1010	100	SINGLE FAMILY				1	1 of 1	
PMT NO	PMT DT	TY	DESC	AMOUNT	INSP	BY	1st	%
980216	05/05/1998	1	NEW CONSTRUC	120,000	08/27/1999	MWS	100	100

LAND

CD	T	AC/SF/UN	Nbhd	Infl1	N Index	ADJ BASE	SAF	Topo	Lpi	VC	CREDIT AMT	ADJ VALUE				
100	S	40,000	1	1.00	100	1.00	100	1.00	259,270	1.00	A	1.00	R04	1.10		238,030
300	A	0.325	1	1.00	100	1.00	100	1.00	17,930	1.00	A	1.00	R04	1.10		5,830

TOTAL	1.243 Acres	ZONING	1	FRNT	148	ASSESSED	CURRENT	PREVIOUS
Nbhd	N SAG	NOTE	LAND	243,900	215,800			
Infl1	AVG		BUILDING	412,400	364,900			
N_Index	AVG		DETACHED	0	0			
			OTHER	0	0			
			TOTAL	656,300	580,700			

DETACHED

TY	QUAL	COND	DIM/NOTE	YB	UNITS	ADJ PRICE	RCNLD	PHOTO
								10/27/2017

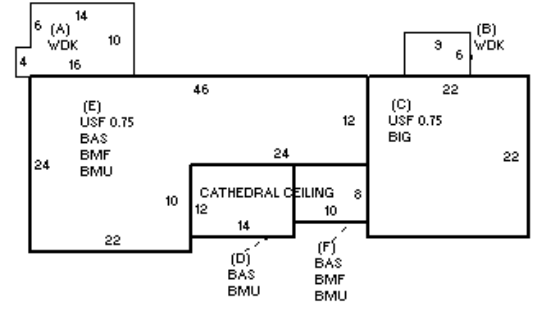
BUILDING

BUILDING	CD	ADJ	DESC	MEASURE	7/20/2021	NMP
MODEL	1		RESIDENTIAL	LIST	10/27/2017	EST
STYLE	4	1.05	CAPE [100%]	REVIEW	1/2/2019	DB
QUALITY	+	1.05	AVERAGE + [100%]			
FRAME	1	1.00	WOOD FRAME [100%]			

YEAR BLT	1998	SIZE ADJ	1.005	ELEMENT	CD	DESCRIPTION	ADJ	S	BAT	T	DESCRIPTION	UNITS	YB	ADJ PRICE	RCN	TOTAL RCN	502,931
NET AREA	2,011	DETAIL ADJ	1.000	FOUNDATION	4	FLR/WALL(FULL)	1.00	+	WDK	N	WOOD DECK	202		29.79	6,018	CONDITION ELEM	CD
\$NLA(RCN)	\$250	OVERALL	1.090	EXT COVER	2	CLAPBOARD	1.00	C	BIG	N	BUILT-IN GARAGE	484		90.18	43,649	EXTERIOR	A
				ROOF SHAPE	1	GABLE	1.00	+	USF	L	UPPER STORY FIN	975	1998	123.82	120,726	INTERIOR	A
				ROOF COVER	1	ASPH/COMP SHIN	1.00	+	BMU	N	BSMT UNFINISHED	1,036		41.94	43,453	KITCHEN	A
				FLOOR COVER	1	HARDWOOD	1.02	+	BAS	L	BASE AREA	1,036	1998	220.80	228,753	BATHS	A
				INT. FINISH	2	DRYWALL	1.00	E	BMF	N	BSMT FINISH	816		39.92	32,577	HEAT	A
				HEATING/COOLING	2	HOT WATER	1.02	F	BMF	N	BSMT FINISH	80		67.20	5,376	ELECT	A
				FUEL SOURCE	2	GAS	1.00		F21	O	FPL 2S 1OP	1		10,132.30	10,132		
				USE	0		1.00		FIX	O	XTRA FIXTURES	5		2,449.52	12,248		

EFF.YR/AGE	2001 / 21	
COND	18	18 %
FUNC	0	
ECON	0	
DEPR	18	% GD 82
RCNLD	\$412,400	