

Key: 9479

Town of Bourne - Fiscal Year 2024

12/18/2023 6:02 pm SEQ #: 9.699

LEGAL

LAND

DETACHED

BUILDING

CURRENT OWNER				PARCEL ID				LOCATION			
WOOD JACK D & ANN E CHEMIN DU LEVANT 14 GRANDVAUX, 1091 SWITZERLAND				43.3-203-0				35 PARK ST			
TRANSFER HISTORY				DOS	T	SALE PRICE	BK-PG (Cert)				
WOOD JACK D & ANN E				05/14/2004	F		18590-312				
WOOD JACK A & ETALS				05/14/2004	N		18590-313+				
WOOD JACK A & ISABELLE D				09/08/2000	A		()				

CLASS	CLASS%	DESCRIPTION			BN ID	BN	CARD	
1010	100	SINGLE FAMILY				1	1 of 1	
PMT NO	PMT DT	TY	DESC	AMOUNT	INSP	BY	1st	%
141019	11/26/2014	1	NEW CONSTRUC	496,899	08/16/2017	TL	100	100

CD	T	AC/SF/UN	Nbhd	Infl1	N Index	ADJ BASE	SAF	Topo	Lpi	VC	CREDIT AMT	ADJ VALUE
100	S	18,256	11	1.00	100	1.00	1.00		1.00	BA-	2.20	401,000

TOTAL	18,256 SF	ZONING	1	FRNT	0	ASSESSED	CURRENT	PREVIOUS
Nbhd	POC	NOTE			LAND	401,000	354,900	
Infl1	AVG		BUILDING	1,338,200	1,184,000			
N_Index	AVG		DETACHED	0	0			
				OTHER	0	0		
				TOTAL	1,739,200	1,538,900		

TY	QUAL	COND	DIM/NOTE	YB	UNITS	ADJ PRICE	RCNLD



BLDG COMMENTS

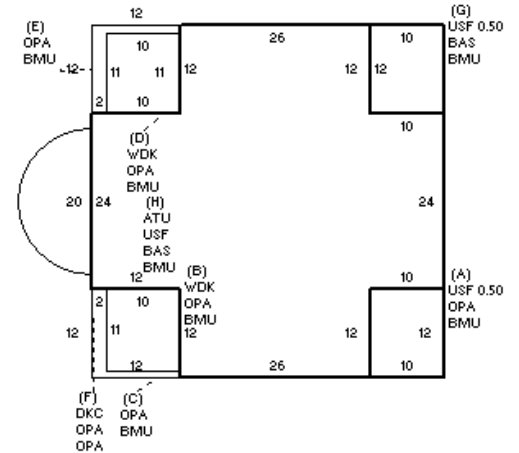

BUILDING	CD	ADJ	DESC	MEASURE	10/20/2016	BC
MODEL	1		RESIDENTIAL	LIST	10/20/2016	EST
STYLE	8	1.10	CONTEMPORARY [100%]	REVIEW	3/20/2017	TL
QUALITY	V	1.35	VERY GOOD [100%]			
FRAME	1	1.00	WOOD FRAME [100%]			

YEAR BLT	2015	SIZE ADJ	0.990	ELEMENT	CD	DESCRIPTION	ADJ	S	BAT	T	DESCRIPTION	UNITS	YB	ADJ PRICE	RCN	TOTAL RCN	1,338,208			
NET AREA	3,792	DETAIL ADJ	1.000	FOUNDATION	4	FLR/WALL(FULL)	1.00	+	BMU	N	BSMT UNFINISHED	2,304		44.93	103,524	CONDITION ELEM	CD			
\$NLA(RCN)	\$353	OVERALL	1.170	EXT COVER	1	WOOD SHINGLE	1.02	+	USF	L	UPPER STORY FIN	1,896	2015	162.58	308,242	EXTERIOR	V			
				ROOF SHAPE	1	GABLE	1.00	+	WDK	N	WOOD DECK	220		40.50	8,910	INTERIOR	G			
				ROOF COVER	1	ASPH/COMP SHIN	1.00	+	OPA	N	OPEN PORCH	722		92.03	66,443	KITCHEN	G			
				FLOOR COVER	1	HARDWOOD	1.02	F	DKC	N	DECK-COMPOSITE	157		98.18	15,415	BATHS	G			
				INT. FINISH	2	DRYWALL	1.00	+	BAS	L	BASE AREA	1,896	2015	276.96	525,111	HEAT	A			
				HEATING/COOLING	9	WARM-COOL AIR	1.03	H	ATU	N	ATTIC UNF	1,776		62.45	110,907	ELECT	A			
				FUEL SOURCE	2	GAS	1.00		BGF	N	BSMT GOOD FINIS	1,844		56.74	104,635					
				USE	0		1.00		F32	O	FPL 3S 2OP	1		15,046.00	15,046					
													FIX	O	XTRA FIXTURES	15	3,330.07	49,951		
													GFP	O	GAS FIREPLACE	3	10,007.70	30,023		
																	EFF.YR/AGE	2021 / 1		
																	COND	1 1 %		
																	FUNC	0		
																	ECON	0		
																	DEPR	0	% GD	100
																	RCNLD	\$1,338,200		