

Key: 9719

Town of Bourne - Fiscal Year 2024

12/18/2023 6:02 pm SEQ #: 9.954

LEGAL

CURRENT OWNER				PARCEL ID				LOCATION			
FRANCIS M CRAIG PO BOX 1267 POCASSET, MA 02559				44.1-6-0				6 VESPER DR			
TRANSFER HISTORY				DOS	T	SALE PRICE	BK-PG (Cert)				
FRANCIS M CRAIG				07/22/2021	F	1 (227006)					
FRANCIS M CRAIG &				08/01/2011	F	1 (194855)					
FRANCIS M CRAIG &				12/31/1981	QS	98,150 (87695)					

CLASS	CLASS%	DESCRIPTION		BN ID	BN	CARD	
1010	100	SINGLE FAMILY			1	1 of 1	
PMT NO	PMT DT	TY	DESC	AMOUNT	INSP	BY	1st %
960068	03/11/1996	3	ALT/RENO	11,000	09/23/1997	JC	100 100
900221	05/10/1990	9	DECK	800	01/01/1991	HS	100 100

LAND

CD	T	AC/SF/UN	Nbhd	Infl1	N Index	ADJ BASE	SAF	Topo	Lpi	VC	CREDIT AMT	ADJ VALUE										
100	S	20,653	11	1.00	100	1.00	100	1.00	271,055	1.66	A	1.00	R08	1.15								213,940

TOTAL	20,647 SF	ZONING	1	FRNT	0	ASSESSED	CURRENT	PREVIOUS
Nbhd	POC	ZONING 1 FRNT 0 N O T E GOLF COURSE VIEWS	LAND	213,900	181,100			
Infl1	AVG		BUILDING	395,300	354,400			
N_Index	AVG		DETACHED	0	0			
			OTHER	0	0			
			TOTAL	609,200	535,500			

TY	QUAL	COND	DIM/NOTE	YB	UNITS	ADJ PRICE	RCNLD

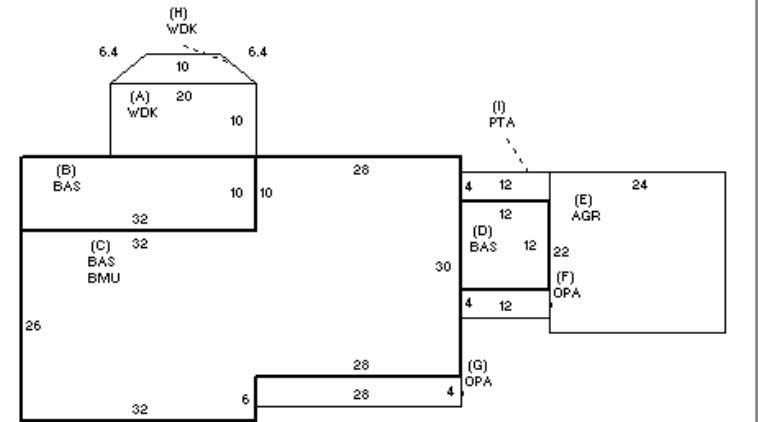

DETACHED

BUILDING	CD	ADJ	DESC	MEASURE	9/5/2008	SAL
MODEL	1		RESIDENTIAL	LIST	9/5/2008	EST
STYLE	1	0.95	RANCH [100%]	REVIEW	9/6/2008	SAL
QUALITY	+	1.05	AVERAGE + [100%]			
FRAME	1	1.00	WOOD FRAME [100%]			

BLDG COMMENTS

BU I L D I N G

YEAR BLT	1981	SIZE ADJ	1.005	ELEMENT	CD	DESCRIPTION	ADJ	S	BAT	T	DESCRIPTION	UNITS	YB	ADJ PRICE	RCN	TOTAL RCN	513,341													
NET AREA	2,136	DETAIL ADJ	1.000	FOUNDATION	4	FLR/WALL(FULL)	1.00	+	WDK	N	WOOD DECK	260		27.60	7,177															
\$NLA(RCN)	\$240	OVERALL	1.010	EXT COVER	4	VINYL	1.00	+	BAS	L	BASE AREA	2,136	1981	183.17	391,257															
				ROOF SHAPE	1	GABLE	1.00	C	BMU	N	BSMT UNFINISHED	1,672		31.60	52,840															
				ROOF COVER	1	ASPH/COMP SHIN	1.00	E	AGR	N	ATT GARAGE	528		65.87	34,780															
				FLOOR COVER	1	HARDWOOD	1.02	+	OPA	N	OPEN PORCH	160		69.66	11,145															
				INT. FINISH	2	DRYWALL	1.00	I	PTA	N	PATIO	48		16.36	786															
				HEATING/COOLING	8	HEAT PUMP	1.04	F11	O	FPL 1S 1OP	1		8,545.60	8,546																
				FUEL SOURCE	1	OIL	1.00	FIX	O	XTRA FIXTURES	3		2,269.80	6,809																
				USE	0		1.00																							
<table border="1"> <thead> <tr> <th>CONDITION ELEM</th> <th>CD</th> </tr> </thead> <tbody> <tr> <td>EXTERIOR</td> <td>A</td> </tr> <tr> <td>INTERIOR</td> <td>A</td> </tr> <tr> <td>KITCHEN</td> <td>A</td> </tr> <tr> <td>BATHS</td> <td>A</td> </tr> <tr> <td>HEAT</td> <td>A</td> </tr> <tr> <td>ELECT</td> <td>A</td> </tr> </tbody> </table>																CONDITION ELEM	CD	EXTERIOR	A	INTERIOR	A	KITCHEN	A	BATHS	A	HEAT	A	ELECT	A	
CONDITION ELEM	CD																													
EXTERIOR	A																													
INTERIOR	A																													
KITCHEN	A																													
BATHS	A																													
HEAT	A																													
ELECT	A																													
<table border="1"> <thead> <tr> <th>EFF.YR/AGE</th> <th colspan="2">1996 / 26</th> </tr> </thead> <tbody> <tr> <td>COND</td> <td>23</td> <td>23 %</td> </tr> <tr> <td>FUNC</td> <td>0</td> <td></td> </tr> <tr> <td>ECON</td> <td>0</td> <td></td> </tr> <tr> <td>DEPR</td> <td>23</td> <td>% GD 77</td> </tr> </tbody> </table>																EFF.YR/AGE	1996 / 26		COND	23	23 %	FUNC	0		ECON	0		DEPR	23	% GD 77
EFF.YR/AGE	1996 / 26																													
COND	23	23 %																												
FUNC	0																													
ECON	0																													
DEPR	23	% GD 77																												
<table border="1"> <thead> <tr> <th>RCNLD</th> <th>\$395,300</th> </tr> </thead> </table>																RCNLD	\$395,300													
RCNLD	\$395,300																													