

Key: 9855

Town of Bourne - Fiscal Year 2024

12/18/2023 6:02 pm SEQ #: 10.088

LEGAL

LAND

DETACHED

BUILDING

CURRENT OWNER		PARCEL ID		LOCATION	
BRUSH BARBARA A P O BOX 745 POCASSET, MA 02559-0745		44.2-14-0		42 WILLIAMS AVE	
TRANSFER HISTORY		DOS	T	SALE PRICE	BK-PG (Cert)
BRUSH BARBARA A		09/28/1989	XX		6898-82

CLASS	CLASS%	DESCRIPTION		BN ID	BN	CARD	
1010	100	SINGLE FAMILY			1	1 of 1	
PMT NO	PMT DT	TY	DESC	AMOUNT	INSP	BY	%
EXB-21-926 350089	12/13/2021 06/13/1989	3 9	ALT/RENO DECK	4,844	12/29/1989	HLD	100 100

CD	T	AC/SF/UN	Nbhd	Infl1	N Index	ADJ BASE	SAF	Topo	Lpi	VC	CREDIT AMT	ADJ VALUE					
100	S	8,000	11	1.00	100	1.00	100	1.00	282,840	3.84	A	1.00	PAV	1.20			199,410

TOTAL	8,015 SF	ZONING	1	FRNT	0	ASSESSED	CURRENT	PREVIOUS
Nbhd	POC	NOTE	LAND	199,400	176,500			
Infl1	AVG		BUILDING	204,600	181,100			
N_Index	AVG		DETACHED	0	0			
			OTHER	0	0			
			TOTAL	404,000	357,600			

TY	QUAL	COND	DIM/NOTE	YB	UNITS	ADJ PRICE	RCNLD

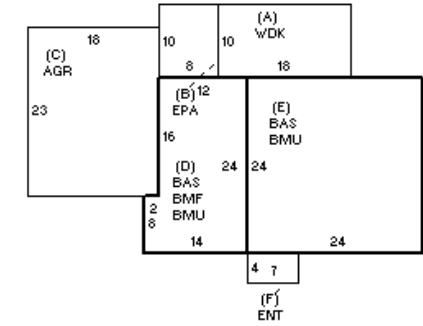

BUILDING	CD	ADJ	DESC	MEASURE	8/9/2008	RJM
MODEL	1		RESIDENTIAL	LIST	8/9/2008	EST
STYLE	1	0.95	RANCH [100%]	REVIEW	8/3/2010	DB
QUALITY	A	1.00	AVERAGE [100%]			
FRAME	1	1.00	WOOD FRAME [100%]			

BLDG COMMENTS

YEAR BLT	1968	SIZE ADJ	1.020	ELEMENT	CD	DESCRIPTION	ADJ	S	BAT	T	DESCRIPTION	UNITS	YB	ADJ PRICE	RCN	TOTAL RCN	262,315
NET AREA	880	DETAIL ADJ	1.000	FOUNDATION	4	FLR/WALL(FULL)	1.00	A	WDK	N	WOOD DECK	180		34.61	6,229		
\$NLA(RCN)	\$298	OVERALL	0.970	EXT COVER	1	WOOD SHINGLE	1.02	B	EPA	N	ENCLOSED PORCH	80		80.57	6,446		
				ROOF SHAPE	1	GABLE	1.00	C	AGR	N	ATT GARAGE	414		61.15	25,316		
				ROOF COVER	1	ASPH/COMP SHIN	1.00	+	BMF	N	BSMT UNFINISHED	880		36.08	31,749		
				FLOOR COVER	3	W/W CARPET	1.00	D	BMF	N	BSMT FINISH	304		57.81	17,575		
				INT. FINISH	2	DRYWALL	1.00	+	BAS	L	BASE AREA	880	1968	196.20	172,658		
				HEATING/COOLING	1	FORCED AIR	1.00	F	ENT	N	ENCLOSED ENTRY	28		83.64	2,342		
				FUEL SOURCE	2	GAS	1.00										
				USE	0		1.00										
																CONDITION ELEM	CD
																EXTERIOR	G
																INTERIOR	A
																KITCHEN	A
																BATHS	A
																HEAT	A
																ELECT	A
																EFF.YR/AGE	1997 / 25
																COND	22 22 %
																FUNC	0
																ECON	0
																DEPR	22 % GD 78
																RCNLD	\$204,600