

Key: 1008

Town of BREWSTER - Fiscal Year 2025

9/17/2024 2:15 pm SEQ #: 1.118

LEG
AL
LAND

CURRENT OWNER				PARCEL ID				LOCATION								
DOWNEY SEAN F & LANA B 76 BUBIER ROAD MARBLEHEAD, NY 01945				103-11-0				18 MUSKRAT LANE								
TRANSFER HISTORY				DOS	T	SALE PRICE	BK-PG (Cert)									
DOWNEY SEAN F & LANA B				09/16/2016	QS	2,505,000	29936-160									
AMUNDSON ANTHONY P & MART				10/25/2013	F		27784-116									
AMUNDSON ANTHONY P & MART				11/23/1998	QS	500,000	11861-239									
CD	T	AC/SF/UN	Nbhd	St Ind	Infl	ADJ BASE	SAF	Topo	Lpi	VC	CREDIT AMT	ADJ VALUE				
100	S	44,004	7	1.00	A	1.00	A	1.00	2,498,880	1.23	5	0.95	BSB	12.00		3,112,520

CLASS	CLASS%	DESCRIPTION			BN ID	BN	CARD	
1010	100	SINGLE FAMILY				1	1 of 1	
PMT NO	PMT DT	TY	DESC	AMOUNT	INSP	BY	1st	%
607	11/07/2008	2	ADD	10,000	03/30/2009	JH	100	100
NP		12	CYCLICAL NON		11/06/2007	JH	100	100
401	07/07/2000	5	OTHER	26,000	05/07/2002	SJM	100	100
514	09/09/1999	5	OTHER	10,000	01/19/2000	LB	100	100
257	05/19/1999	1	NEW CONSTRUC	600,000	01/19/2000	LB	100	100

DE
T
A
C
H
E
D

TOTAL	1.010 Acres	ZONING	RM	FRNT	0	ASSESSED	CURRENT	PREVIOUS
Nbhd	NBHD 7	NOTE				LAND	3,112,500	2,936,500
St Ind	AVERAGE		LAND	1,410,300	1,332,500			
Infl	AVERAGE		BUILDING	5,000	4,900			
			DETACHED	0	0			
					OTHER	0	0	
					TOTAL	4,527,800	4,273,900	

BU
IL
D
ING

TY	QUAL	COND	DIM/NOTE	YB	UNITS	ADJ PRICE	RCNLD	PHOTO	01/21/2021
PTD	G	1.20	10 0.90	18X38		684	8.10	5,000	

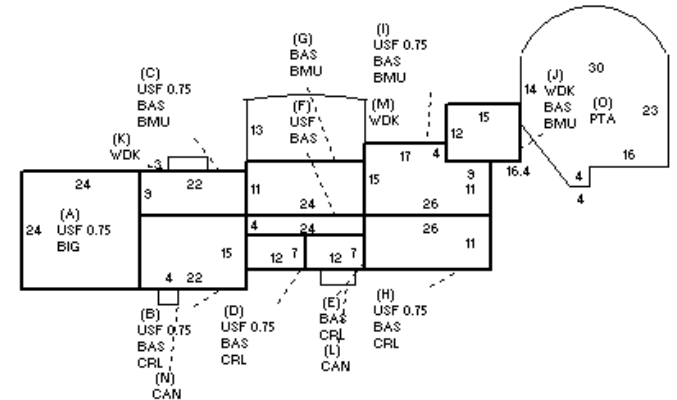

RE
V
I
E
W

BUILDING	CD	ADJ	DESC	MEASURE	1/21/2021	NF
MODEL	1		RESIDENTIAL	LIST	11/6/2007	JH
STYLE	8	0.95	CONTEMPOR [100%]	REVIEW	3/1/2021	MR
QUALITY	E	2.10	EXCELLENT [100%]			
FRAME	1	1.00	WD FRAME [100%]			

BLDG COMMENTS
GENERATOR

YEAR BLT	1999	SIZE ADJ	0.980	ELEMENT	CD	DESCRIPTION	ADJ	S	BAT	T	DESCRIPTION	UNITS	YB	ADJ PRICE	RCN	TOTAL RCN	1,699,178
NET AREA	3,343	DETAIL ADJ	1.000	FOUNDATION	4	FLR & WALL	1.00	A	BIG	N	BUILT-IN GARAGE	576		97.14	55,955		
\$NLA(RCN)	\$508	OVERALL	0.970	EXT COVER	1	WD SHINGLE	1.00	+	USF	L	UPPER STORY FIN	1,467	1999	322.07	472,475		
				ROOF SHAPE	1	GABLE	1.00	B	CRL	N	BSMT CRAWL	330		60.61	20,003		
				ROOF COVER	2	WD SHINGLE	1.01	+	BMU	N	BSMT UNFINISHED	996		117.78	117,308		
				FLOOR COVER	1	HARDWOOD	1.00	D	CRL	N	BSMT CRAWL	84		60.63	5,093		
				INT FINISH	3	WD PANEL	1.00	E	CRL	N	BSMT CRAWL	84		60.63	5,093		
				HEATING/COOL	15	HTWT+DCTLS AC	1.01	+	BAS	L	BASE AREA	1,876	1999	462.55	867,750		
				FUEL SOURCE	2	GAS	1.00	H	CRL	N	BSMT CRAWL	286		60.61	17,336		
								+	WDK	N	WOOD DECK	532		78.25	41,630		
								L	CAN	N	CANOPY	21		93.06	1,954		
								N	CAN	N	CANOPY	12		92.99	1,116		
								O	PTA	N	PATIO	898		23.81	21,378		
								F22	O	FPL 2S 2OP	1		24,897.40	24,897			
								ODS	O	OUTDOOR SHOWER	1		4,821.00	4,821			
																CONDITION ELEM	CD
																EXTERIOR	A
																INTERIOR	A
																KITCHEN	A
																BATHS	A
																HEAT/ELEC	A
																EFF.YR/AGE	1999 / 24
																COND	17 17 %
																FUNC	0
																ECON	0
																DEPR	17 % GD 83
																RCNLD	\$1,410,300