

Key: 1056

Town of BREWSTER - Fiscal Year 2025

9/17/2024 2:15 pm SEQ #: 1.164

LEG
AL
LAND

CURRENT OWNER				PARCEL ID				LOCATION					
BARKHUFF STEPHEN & SARAH PO BOX 1466 BREWSTER, MA 02631				115-49-0				216 MITCHELL LANE					
TRANSFER HISTORY				DOS	T	SALE PRICE	BK-PG (Cert)						
BARKHUFF STEPHEN & SARAH				11/17/2021	QS	1,765,000	34670-115						
BEAUCHEMIN BRUCE A & MICH				02/15/2000	QS	855,000	12831-346						
HUGHES VERA ELIZABETH				09/30/1994	QS	400,000	9389-128						
CD	T	AC/SF/UN	Nbhd	St Ind	Infl	ADJ BASE	SAF	Topo	Lpi	VC	CREDIT AMT	ADJ VALUE	
100	S	60,000	8	1.00	8-A	1.00	A	1.00	767,200	1.00	A	1.00	1,061,720
300	A	1,065	8	1.00	8-A	1.00	A	1.00	42,000	1.00	A	1.00	44,730
350	A	0,473	8	1.00	8-A	1.00	A	1.00	2,100	1.00	A	1.00	990

CLASS	CLASS%	DESCRIPTION			BN ID	BN	CARD	
1010	100	SINGLE FAMILY				1	1 of 1	
PMT NO	PMT DT	TY	DESC	AMOUNT	INSP	BY	1st	%
24-75	03/04/2024	7	ALTERATIONS	17,785				0
23-101	02/14/2023	7	ALTERATIONS	120,000	05/02/2024	NF	100	100
	11/17/2021	15	SALE REVIEW	1,765,000	06/09/2022	JMG	100	100
		18	OWNER REQUES		05/21/2020	JMG	100	100
674	09/04/2015	7	ALTERATIONS		04/26/2016	WFF	100	100

TOTAL	2.915 Acres				ZONING	RR	FRNT	0		
Nbhd	NBHD 8				N O T E	FY21 adjust sf per plan Bk 380 Pg 11				
St Ind	SEAVIEW RD					LAND	1,107,400	1,044,700		
Infl	AVERAGE					BUILDING	937,100	842,600		
						DETACHED	31,500	31,200		
						OTHER	0	0		
						TOTAL	2,076,000	1,918,500		

TY	QUAL	COND	DIM/NOTE	YB	UNITS	ADJ PRICE	RCNLD
GFU	A	1.00	10 0.90	26X30	780	44.90	31,500

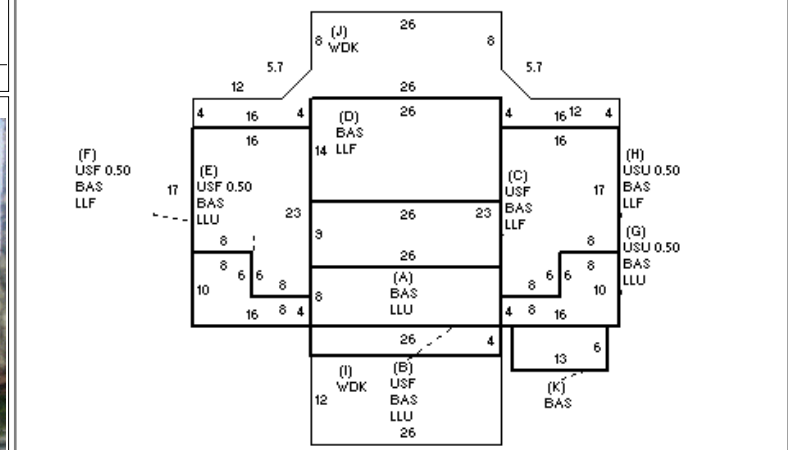

BUILDING	CD	ADJ	DESC	MEASURE	5/21/2020	JMG
MODEL	1		RESIDENTIAL	LIST	5/21/2020	JMG
STYLE	4	1.02	CAPE [100%]	REVIEW	5/21/2024	EMZ
QUALITY	G	1.30	GOOD [100%]			
FRAME	1	1.00	WD FRAME [100%]			

BLDG COMMENTS

YEAR BLT	1989	SIZE ADJ	0.970
NET AREA	3,748	DETAIL ADJ	1.000
\$NLA(RCN)	\$298	OVERALL	1.070
CAPACITY		UNITS	ADJ
STORIES	2	1.00	
ROOMS	10	1.00	
BEDROOMS	4	1.00	
BATHROOMS	2	1.00	
FIXTURES	10	\$18,083	
GARAGE SPACES	2	1.00	
% BSMT FIN	70	1.00	
# 1/2 BATHS	1	1.00	
# OF UNITS	1	1.00	

ELEMENT	CD	DESCRIPTION	ADJ	S	BAT	T	DESCRIPTION	UNITS	YB	ADJ PRICE	RCN	TOTAL RCN	1,115,567
FOUNDATION	4	FLR & WALL	1.00	+	LLU	N	LOWER LEVEL UNF	536		120.52	64,598		
EXT COVER	1	WD SHINGLE	1.00	+	BAS	L	BASE AREA	468	1989	312.64	146,315		
ROOF SHAPE	1	GABLE	1.00	+	BAS	L	BASE AREA	1,306	1989	312.64	408,307		
ROOF COVER	1	ASPH/CMP SH	1.00	+	USF	L	UPPER STORY FIN	658	1989	248.06	163,224		
FLOOR COVER	2	SOFTWOOD	1.00	+	LLF	L	LOWER LEVEL FIN	1,238	1989	159.08	196,939		
INT FINISH	2	DRYWALL	1.00	+	USU	N	UPPER STORY UNF	216		76.14	16,446		
HEATING/COOL	11	HTWT/CL AIR	1.05	+	WDK	N	WOOD DECK	768		52.89	40,621		
FUEL SOURCE	1	OIL	1.00										
				K	BAS	L	BASE AREA	78	2007	312.63	24,385		
					F23	O	FPL 2S 3OP	1		26,607.60	26,608		
					GEN	O	GENERATOR	1		0.00			
					MST	O	MAS/METAL STACK	1		6,782.80	6,783		
					ODS	O	OUTDOOR SHOWER	1		3,258.50	3,259		

CONDITION ELEM	CD
EXTERIOR	A
INTERIOR	A
KITCHEN	E
BATHS	A
HEAT/ELEC	A

EFF.YR/AGE	2001 / 22	
COND	16	16 %
FUNC	0	
ECON	0	
DEPR	16	% GD 84

RCNLD	\$937,100
-------	-----------