

Key: 1197

Town of BREWSTER - Fiscal Year 2025

9/17/2024 2:15 pm SEQ #: 1.302

LEGAL

CURRENT OWNER				PARCEL ID				LOCATION			
MASSACHUSETTS COMMONWEALTH OF CAMP MONOMOY 251 CAUSEWAY STREET SUITE 600 BOSTON, MA 02114				114-1-0				3299 MAIN STREET			
TRANSFER HISTORY				DOS	T	SALE PRICE	BK-PG (Cert)				
MASSACHUSETTS COMMONWEALTH				02/10/1984	XX	1,800,000	4012-205				

CLASS	CLASS%	DESCRIPTION			BN ID	BN	CARD
9100	100	DEPT CON&REC.ST PARK				1	1 of 1
PMT NO	PMT DT	TY	DESC	AMOUNT	INSP	BY	1st %

LAND

CD	T	AC/SF/UN	Nbhd	St Ind	Infl	ADJ BASE	SAF	Topo	Lpi	VC	CREDIT AMT	ADJ VALUE				
100	S	60,000	7	1.00	38	1.00	A	1.00	1,468,640	1.00	A	1.00	BVG	6.70		2,032,430
200	A	22,039	7	1.00	38	1.00	A	1.00	807,350	1.00	A	1.00	BVG	6.70		17,793,190
300	A	21,644	7	1.00	38	1.00	A	1.00	80,400	1.00	A	1.00	BVG	6.70		1,740,180

DETAILED

TOTAL	45.060 Acres	ZONING	RM	FRNT	780	ASSESSED	CURRENT	PREVIOUS
Nbhd	NBHD 7	N SOL=17 PRIME SITES O 2@5.8/4@2.8/1@2.4/2@1.6/3@1.35/5@1.0				LAND	21,565,800	20,345,200
St Ind	SACHEM-ORLEANS	T				BUILDING	296,300	279,700
Infl	AVERAGE	E				DETACHED	533,500	528,500
						OTHER	0	0
						TOTAL	22,395,600	21,153,400

TY	QUAL	COND	DIM/NOTE	YB	UNITS	ADJ PRICE	RCNLD	PHOTO
CBN	A	1.00	40 0.60		13,082	44.90	352,400	
SHF	A	1.00	50 0.50		536	16.12	4,300	
CBH	A	1.00	40 0.60		1,296	26.90	20,900	
CBH	A	1.00	20 0.80		6,908	26.90	148,700	
DGF	A	1.00	50 0.50		480	30.15	7,200	

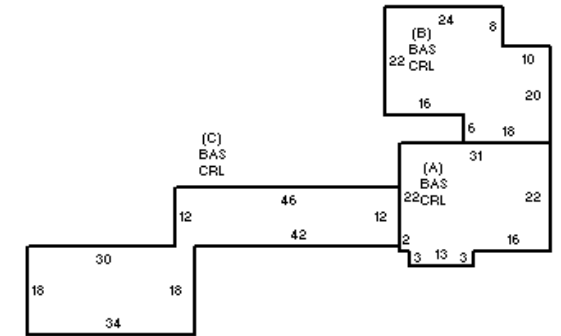

BUILDING

BUILDING	CD	ADJ	DESC	MEASURE	6/1/1991	DH
MODEL	1		RESIDENTIAL	LIST	6/1/1991	EST
STYLE	5	1.05	COLONIAL [100%]	REVIEW	1/6/2010	DHT
QUALITY	A	1.00	AVG [100%]	BLDG COMMENTS cape repertory theatre		
FRAME	1	1.00	WD FRAME [100%]			

INDING

YEAR BLT	1890	SIZE ADJ	0.990	ELEMENT	CD	DESCRIPTION	ADJ	S	BAT	T	DESCRIPTION	UNITS	YB	ADJ PRICE	RCN	TOTAL RCN	740,865		
NET AREA	2,661	DETAIL ADJ	1.000	FOUNDATION	1	PIER	1.00	A	CRL	N	BSMT CRAWL	721		29.42	21,211	CONDITION ELEM CD			
\$NLA(RCN)	\$278	OVERALL	1.050	EXT COVER	1	WD SHINGLE	1.00	+	BAS	L	BASE AREA	2,661	1890	230.61	613,662	EXTERIOR			
				ROOF SHAPE	1	GABLE	1.00	B	CRL	N	BSMT CRAWL	776		29.42	22,829	INTERIOR			
				ROOF COVER	1	ASPH/CMP SH	1.00	C	CRL	N	BSMT CRAWL	1,164		26.66	31,033	KITCHEN			
				FLOOR COVER	2	SOFTWOOD	1.00		ASH	N	ATT SHED	64		29.07	1,861	BATHS			
				INT FINISH	2	DRYWALL	1.00		ATF	N	ATTIC FINISH	359		80.04	28,735	HEAT/ELEC			
				HEATING/COOL	1	FORCED AIR	1.00		OPA	N	OPEN PORCH	80		51.98	4,158				
				FUEL SOURCE	1	OIL	1.00		F21	O	FPL 2S 1OP	1		10,552.00	10,552				
																	EFF.YR/AGE	1941 / 82	
																	COND	40 40 %	
																	FUNC	0	
																	ECON	20 AGE	
																	DEPR	60 % GD 40	
																	RCNLD	\$296,300	