

Key: 12110

Town of BREWSTER - Fiscal Year 2025

9/17/2024 2:15 pm SEQ #: 9.054

LEGAL

LAND

DETACHED

BUILDING

CURRENT OWNER										PARCEL ID				LOCATION			
PFANNENSTIEHL CRAIG F & BERGSTROM CHRISTY A TRUSTEES 101 DEER PATH LANE WESTON, MA 02493										50-92-0				91 CARVER ROAD			
TRANSFER HISTORY										DOS	T	SALE PRICE		BK-PG (Cert)			
										12/26/2012	F	10		(199166)			
										12/15/1997	QS	700,000		(146879)			
										04/05/1974	N	N/A-N/A		N/A-N/A			

CLASS	CLASS%	DESCRIPTION			BN ID	BN	CARD	
1010	100	SINGLE FAMILY				1	1 of 1	
PMT NO	PMT DT	TY	DESC	AMOUNT	INSP	BY	1st	%
227	04/04/2007	7	ALTERATIONS	8,000	10/20/2007	JH	100	100
119	02/26/2007	7	ALTERATIONS	500,000	10/20/2007	JH	100	100
345	06/06/2000	5	OTHER	23,000			100	100
472	08/20/1999	5	OTHER	25,000	01/06/2000	LB	100	100
102	03/04/1999	2	ADD	15,000	01/06/2000	LB	100	100

CD	T	AC/SF/UN	Nbhd	St Ind	Infl	ADJ BASE	SAF	Topo	Lpi	VC	CREDIT AMT	ADJ VALUE
100	S	60,000 3	1.00	3A	1.00	A	1.00					3,640,170
300	A	0.803 3	1.00	3A	1.00	A	1.00					115,630

TOTAL	2.180 Acres	ZONING	RM	FRNT	0	ASSESSED	CURRENT	PREVIOUS
Nbhd	NBHD 3	N O T E	SUBDIV OF LOT 154 FOR F/Y 99			LAND	3,755,800	3,543,100
St Ind	BREWSTER PARK		BUILDING	2,311,700	2,183,200			
Infl	AVERAGE		DETACHED	24,900	24,600			
			OTHER	0	0			
						TOTAL	6,092,400	5,750,900

TY	QUAL	COND	DIM/NOTE	YB	UNITS	ADJ PRICE	RCNLD
DGF	A	1.00	20 0.80 24 X 28	2000	672	27.67	14,900
STU	A	1.00	20 0.80 7 X 20	2000	140	50.00	5,600
PTD	A	1.00	30 0.70 28X23		644	6.75	3,000
OPA	A	1.00	20 0.80 5X20 ATT TO	2000	100	17.75	1,400



BLDG COMMENTS

BUILDING	CD	ADJ	DESC	MEASURE	3/14/2018	NF
MODEL	1		RESIDENTIAL	LIST	10/18/2007	JH
STYLE	5	1.05	COLONIAL [100%]	REVIEW	12/20/2019	MR
QUALITY	E	2.10	EXCELLENT [100%]			
FRAME	1	1.00	WD FRAME [100%]			

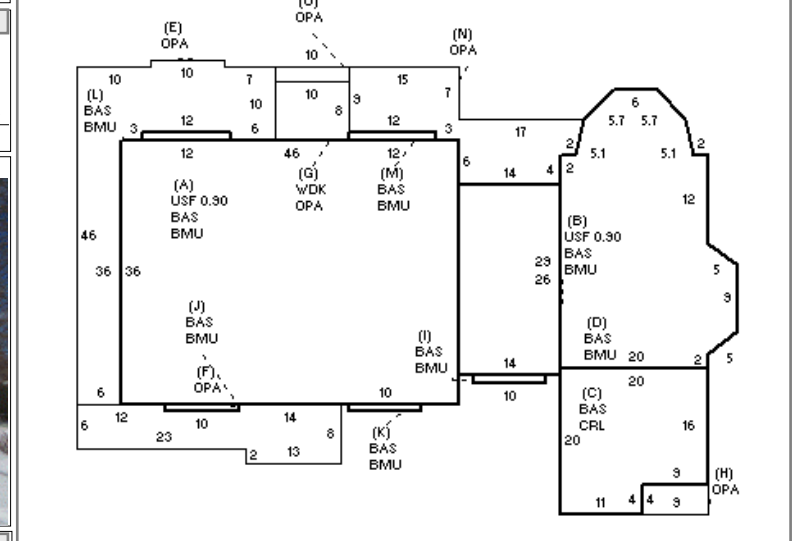

YEAR BLT	1999	SIZE ADJ	0.970	ELEMENT	CD	DESCRIPTION	ADJ	S	BAT	T	DESCRIPTION	UNITS	YB	ADJ PRICE	RCN	TOTAL RCN	2,785,182		
NET AREA	4,999	DETAIL ADJ	1.000	FOUNDATION	4	FLR & WALL	1.00	+	BMU	N	BSMT UNFINISHED	2,817		103.79	292,370	CONDITION ELEM	CD		
\$NLA(RCN)	\$557	OVERALL	1.110	EXT COVER	1	WD SHINGLE	1.00	+	BAS	L	BASE AREA	3,181	1999	501.62	1,595,648			EXTERIOR	A
																		INTERIOR	A
																		KITCHEN	A
																		BATHS	A
																		HEAT/ELEC	A
																		EFF.YR/AGE	1999 / 24
																		COND	17 17 %
																		FUNC	0
																		ECON	0
																DEPR	17 % GD 83		
																RCNLD	\$2,311,700		