

Key: 12113

Town of BREWSTER - Fiscal Year 2025

9/17/2024 2:15 pm SEQ #: 9.057

LEG
AL
LAND

| CURRENT OWNER | | | | PARCEL ID | | | | LOCATION | | | | |
|--|--|--|--|---------------------------|---|---------|-----------|------------------|---|------------|--------------|--|
| BLOOMER JAMES A & KATHLEEN C & LONG JOHN P JR & PATRICIA D C/O PATRICIA LONG 313 WILLIAMSBURG DRIVE SILVER SPRINGS, MD 20901 | | | | 38-93-0 | | | | 100 BLOOMER PATH | | | | |
| | | | | TRANSFER HISTORY | | | | DOS | T | SALE PRICE | BK-PG (Cert) | |
| | | | | BLOOMER JAMES A & KATHLEE | | | | 11/15/2001 | A | 14444-283 | | |
| BLOOMER JAMES A & KATHLEE | | | | 11/05/1996 | N | 279,000 | 10470-087 | | | | | |

| CLASS | CLASS% | DESCRIPTION | | | BN ID | BN | CARD | |
|--------|------------|---------------|--------------|--------|------------|-----|--------|-----|
| 1010 | 100 | SINGLE FAMILY | | | | 1 | 1 of 1 | |
| PMT NO | PMT DT | TY | DESC | AMOUNT | INSP | BY | 1st | % |
| 2023-1 | 07/19/2021 | 13 | SPLIT/SUB/LA | | 06/17/2022 | JMG | 100 | 100 |
| NP | | 12 | CYCLICAL NON | | 11/29/2007 | JH | 100 | 100 |
| 31 | 01/20/2005 | 2 | ADD | 20,000 | 04/11/2006 | JB | 100 | 100 |
| 46 | 02/02/1999 | 2 | ADD | 35,000 | 01/03/2000 | LB | 100 | 100 |

| CD | T | AC/SF/UN | Nbhd | St Ind | Infl | ADJ BASE | SAF | Topo | Lpi | VC | CREDIT AMT | ADJ VALUE |
|-----|---|----------|------|--------|------|----------|-----|------|-----|------|------------|-----------|
| 100 | S | 60,000 | 11 | 1.00 | A | 1.00 | A | 1.00 | R07 | 1.70 | | 515,690 |
| 300 | A | 0.571 | 11 | 1.00 | A | 1.00 | A | 1.00 | R07 | 1.70 | | 11,650 |

| TOTAL | 1.948 Acres | | ZONING | RM | FRNT | 0 | ASSESSED | CURRENT | PREVIOUS |
|--------|-------------|--|--------|--|------|---|----------|---------|----------|
| Nbhd | NBHD 11 | | N | FY23 Subdivision per Plan Bk 691 Pg 39. This portion (Lot 3) remains 38-93-0 | | | LAND | 527,300 | 497,500 |
| St Ind | AVERAGE | | O | FY99 Subdivision per Plan Bk 533 Pg 21 changed to #100 Bloomer Path per FD | | | BUILDING | 360,500 | 340,400 |
| Infl | AVERAGE | | T | 7/15/04 | | | DETACHED | 1,100 | 1,100 |
| | | | E | | | | OTHER | 0 | 0 |
| | | | | | | | TOTAL | 888,900 | 839,000 |

| TY | QUAL | COND | DIM/NOTE | YB | UNITS | ADJ PRICE | RCNLD |
|-----|------|------|---------------|----|-------|-----------|-------|
| PTD | A | 1.00 | 30 0.70 10X18 | | 180 | 8.55 | 1,100 |

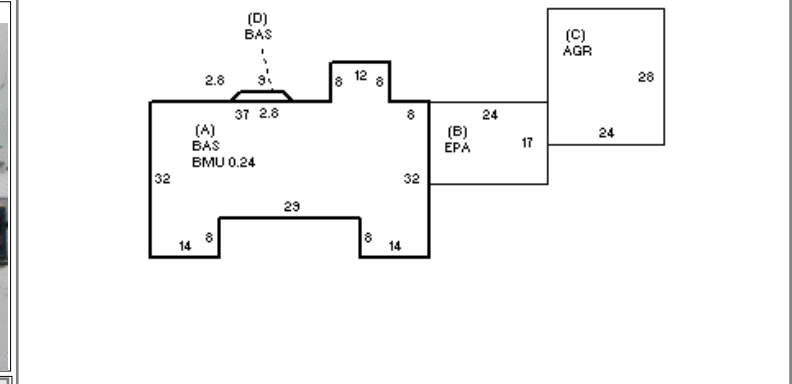

| BUILDING | CD | ADJ | DESC | MEASURE | 2/20/2021 | NF |
|----------|----|------|-----------------|---------|-----------|-----|
| MODEL | 1 | | RESIDENTIAL | LIST | 2/20/2021 | EST |
| STYLE | 1 | 1.00 | RANCH [100%] | REVIEW | 3/8/2021 | MR |
| QUALITY | A+ | 1.20 | AVG + [100%] | | | |
| FRAME | 1 | 1.00 | WD FRAME [100%] | | | |

BLDG COMMENTS

DET
ACHED

B
U
I
L
D
I
N
G

| YEAR BLT | 1930 | SIZE ADJ | 1.000 | ELEMENT | CD | DESCRIPTION | ADJ | S | BAT | T | DESCRIPTION | UNITS | YB | ADJ PRICE | RCN | TOTAL RCN | 600,914 | | |
|------------|-------|------------|-------|--------------|----|-------------|------|-----|-----|----------------|-----------------|-------|----------|-----------|-----------|----------------|---------|------------|------------|
| NET AREA | 1,710 | DETAIL ADJ | 1.000 | FOUNDATION | 5 | OTHER | 1.00 | A | BMU | N | BSMT UNFINISHED | 405 | | 80.22 | 32,488 | CONDITION ELEM | CD | | |
| \$NLA(RCN) | \$351 | OVERALL | 1.000 | EXT COVER | 1 | WD SHINGLE | 1.00 | B | EPA | N | ENCLOSED PORCH | 408 | | 77.28 | 31,530 | EXTERIOR | A | | |
| | | | | ROOF SHAPE | 1 | GABLE | 1.00 | C | AGR | N | ATT GARAGE | 672 | | 44.48 | 29,890 | INTERIOR | A | | |
| | | | | ROOF COVER | 1 | ASPH/CMP SH | 1.00 | + | BAS | L | BASE AREA | 1,710 | 1930 | 283.97 | 485,585 | KITCHEN | A | | |
| | | | | FLOOR COVER | 1 | HARDWOOD | 1.00 | F11 | O | FPL 1S 1OP | 1 | | 9,164.00 | 9,164 | BATHS | A | | | |
| | | | | INT FINISH | 1 | PLASTER | 1.00 | ODS | O | OUTDOOR SHOWER | 1 | | 2,898.00 | 2,898 | HEAT/ELEC | A | | | |
| | | | | HEATING/COOL | 2 | HOT WATER | 1.00 | | | | | | | | | | | | |
| | | | | FUEL SOURCE | 1 | OIL | 1.00 | | | | | | | | | | | | |
| | | | | | | | | | | | | | | | | | | EFF.YR/AGE | 1933 / 90 |
| | | | | | | | | | | | | | | | | | | COND | 40 40 % |
| | | | | | | | | | | | | | | | | | | FUNC | 0 |
| | | | | | | | | | | | | | | | | | | ECON | 0 |
| | | | | | | | | | | | | | | | | | | DEPR | 40 % GD 60 |
| | | | | | | | | | | | | | | | | | | RCNLD | \$360,500 |