

Key: 1215

Town of BREWSTER - Fiscal Year 2025

9/17/2024 2:15 pm SEQ #: 1.324

LEG  
AL  
LAND

CURRENT OWNER				PARCEL ID				LOCATION			
FRASER ANN TRUSTEE 59 BONNIE DOONE CARTWAY TRUST THIRWOOD PLACE APT 259 237 NORTH MAIN STREET SOUTH YARMOUTH, MA 02664				102-2-0				59 BONNIE DOONE CARTWAY			
TRANSFER HISTORY				DOS	T	SALE PRICE	BK-PG (Cert)				
FRASER ANN TRUSTEE				10/13/2006	F	10	21429-125				
BECKETT ANN UNDERHILL				09/25/1984	XX	87,500	4261-149				

CLASS	CLASS%	DESCRIPTION		BN ID	BN	CARD	
1010	100	SINGLE FAMILY			1	1 of 1	
PMT NO	PMT DT	TY	DESC	AMOUNT	INSP	BY	1st %
NP 45	02/03/2000	14	CYCLICAL GRO		01/26/2021	NF	100 100
		12	CYCLICAL NON		10/26/2007	JH	100 100
		9	HVAC	10,000			100 100

DE  
T  
A  
C  
H  
E  
D

TOTAL	38,100 SF	ZONING	RM	FRNT	0	ASSESSED	CURRENT	PREVIOUS
Nbhd	NBHD 7	NOTE				LAND	495,200	467,200
St Ind	AVERAGE		BUILDING	312,100	294,700			
Infl	AVERAGE		DETACHED	8,000	7,900			
			OTHER	0	0			
						TOTAL	815,300	769,800

TY	QUAL	COND	DIM/NOTE	YB	UNITS	ADJ PRICE	RCNLD
DGF	A	1.00	30 0.70 14X23		322	31.80	7,200
SHF	A	1.00	30 0.70 3X16		48	22.94	800

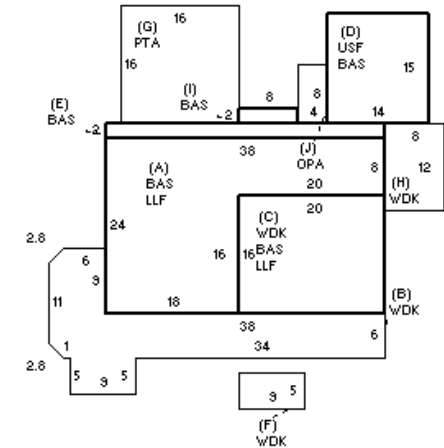

B  
U  
I  
L  
D  
I  
N  
G

BUILDING	CD	ADJ	DESC	MEASURE	1/26/2021	NF
MODEL	1		RESIDENTIAL	LIST	10/26/2007	JH
STYLE	8	0.95	CONTEMPOR [100%]	REVIEW	3/1/2021	MR
QUALITY	A	1.00	AVG [100%]			
FRAME	1	1.00	WD FRAME [100%]			

BLDG COMMENTS  
LLF=FAM RM/2 BEDROOMS/BATH  
INFO @ DOOR (1/26/2021)

E  
L  
E  
M  
E  
N  
T

YEAR BLT	1963	SIZE ADJ	1.000	ELEMENT	CD	DESCRIPTION	ADJ	S	BAT	T	DESCRIPTION	UNITS	YB	ADJ PRICE	RCN	TOTAL RCN	480,166		
NET AREA	2,336	DETAIL ADJ	1.000	FOUNDATION	4	FLR & WALL	1.00	+	LLF	L	LOWER LEVEL FIN	912	1963	119.69	109,159	CONDITION ELEM	CD		
\$NLA(RCN)	\$206	OVERALL	0.940	EXT COVER	10	VERT BOARD	0.98	+	WDK	N	WOOD DECK	850		36.85	31,321	EXTERIOR	A		
				ROOF SHAPE	4	FLAT/SHED	1.00	+	BAS	L	BASE AREA	1,214	1963	231.71	281,296	INTERIOR	A		
				ROOF COVER	1	ASPH/CMP SH	1.00	D	USF	L	UPPER STORY FIN	210	1963	174.58	36,662	KITCHEN	A		
				FLOOR COVER	3	WW CARPET	1.00	G	PTA	N	PATIO	256		13.45	3,443	BATHS	A		
				INT FINISH	2	DRYWALL	1.00	J	OPA	N	OPEN PORCH	32		47.00	1,504	HEAT/ELEC			
				HEATING/COOL	15	HTWT+DCTLS AC	1.01	F11	O	FPL 1S IOP	1			7,178.80	7,179				
				FUEL SOURCE	1	OIL	1.00	ODS	O	OUTDOOR SHOWER	1			2,270.10	2,270				
																		EFF.YR/AGE	1963 / 60
																		COND	35 35 %
																		FUNC	0
																		ECON	0
																		DEPR	35 % GD 65
																		RCNLD	\$312,100