

Key: 1231

Town of BREWSTER - Fiscal Year 2025

9/17/2024 2:15 pm SEQ #: 1.341

LEG
AL
LAND

CURRENT OWNER				PARCEL ID				LOCATION															
ROSSI LOUIS P & ROSSI ELENA				102-26-0				45 EAGLE WING LANE															
515 TWIN OAKS ROAD				TRANSFER HISTORY				DOS	T	SALE PRICE	BK-PG (Cert)												
UNION, NJ 07083				ROSSI LOUIS P & ROSSI ELE				12/16/2016	QS	395,000	30171-18												
				SZETELA CAROLE E &				06/02/1994	QS	108,000	9220-0091												
CD	T	AC/SF/UN	Nbhd	St Ind	Infl	ADJ BASE	SAF	Topo	Lpi	VC	CREDIT AMT	ADJ VALUE											
100	S	10,600	7	1.00	A	1.00	A	1.00	416,480	3.81	A	1.00	R09	1.90									386,490

CLASS	CLASS%	DESCRIPTION				BN ID	BN	CARD	
1010	100	SINGLE FAMILY					1	1 of 1	
PMT NO	PMT DT	TY	DESC	AMOUNT	INSP	BY	1st	%	
904	10/22/2018	1	NEW CONSTRUC	1,000,000	07/13/2020	NF	100	100	
894	10/18/2018	6	DEMO	10,000	06/26/2019	NF	100	100	
NP		12	CYCLICAL NON		11/05/2007	JH	100	100	
87	03/19/1992	2	ADD		01/01/1995	RD	100	100	

DE
TACH
ED

TOTAL	10,600 SF	ZONING	RM	FRNT	0	ASSESSED	CURRENT	PREVIOUS
Nbhd	NBHD 7	NOTE				LAND	386,500	364,600
St Ind	AVERAGE		LAND	1,292,200	1,233,200			
Infl	AVERAGE		BUILDING	9,000	8,900			
			DETACHED	0	0			
					OTHER			
					TOTAL	1,687,700	1,606,700	

TY	QUAL	COND	DIM/NOTE	YB	UNITS	ADJ PRICE	RCNLD
DGF	A	1.00	20 0.80	16X22	352	31.80	9,000

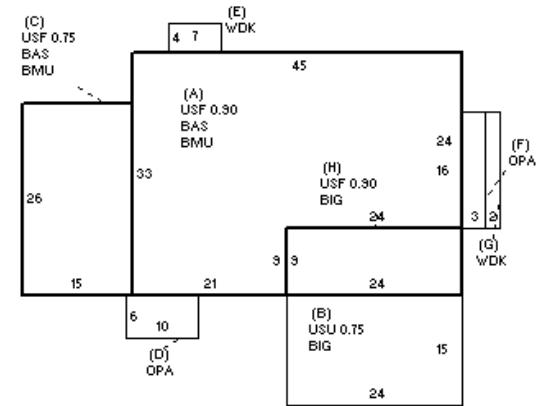

B
U
I
L
D
I
N
G

BUILDING	CD	ADJ	DESC	MEASURE	6/26/2019	NF
MODEL	1		RESIDENTIAL	LIST	7/13/2020	EST
STYLE	4	1.02	CAPE [100%]	REVIEW	7/27/2020	ER
QUALITY	V	1.65	VERY GOOD [100%]			
FRAME	1	1.00	WD FRAME [100%]			

BLDG COMMENTS
PULL DOWN STAIRS TO ATTIC

YEAR BLT	2018	SIZE ADJ	0.980	ELEMENT	CD	DESCRIPTION	ADJ	S	BAT	T	DESCRIPTION	UNITS	YB	ADJ PRICE	RCN	TOTAL RCN	1,360,201		
NET AREA	3,288	DETAIL ADJ	1.000	FOUNDATION	4	FLR & WALL	1.00	+	BMU	N	BSMT UNFINISHED	1,659		86.85	144,085	CONDITION ELEM	CD		
\$NLA(RCN)	\$414	OVERALL	1.050	EXT COVER	1	WD SHINGLE	1.00	+	BAS	L	BASE AREA	1,659	2018	401.78	666,552	EXTERIOR	A		
				ROOF SHAPE	1	GABLE	1.00	+	USF	L	UPPER STORY FIN	1,629	2018	261.18	425,468	INTERIOR	A		
				ROOF COVER	1	ASPH/CMP SH	1.00	B	BIG	N	BUILT-IN GARAGE	360		90.14	32,449	KITCHEN	A		
				FLOOR COVER	1	HARDWOOD	1.00	B	USU	N	UPPER STORY UNF	270		95.81	25,868	BATHS	A		
				INT FINISH	2	DRYWALL	1.00	+	OPA	N	OPEN PORCH	108		84.89	9,168	HEAT/ELEC	A		
				HEATING/COOL	9	WARM/CL AIR	1.03	+	WDK	N	WOOD DECK	60		66.56	3,993				
				FUEL SOURCE	2	GAS	1.00	H	BIG	N	BUILT-IN GARAGE	216		95.77	20,687				
												GFP	O	GAS FIREPLACE	1	5,307.50	5,308		
												ODS	O	OUTDOOR SHOWER	1	4,100.30	4,100		
																EFF.YR/AGE	2018 / 5		
																COND	5 5 %		
																FUNC	0		
																ECON	0		
																DEPR	5 % GD 95		
																RCNLD	\$1,292,200		