

Key: 1279

Town of BREWSTER - Fiscal Year 2025

9/17/2024 2:15 pm SEQ #: 1.391

LEGAL

CURRENT OWNER		PARCEL ID		LOCATION			
VILLANDRY DAVID J & CHERYL A TRUSTEES THE VILLANDRY REVOCABLE TRUST 50 FLYING MIST LANE BREWSTER, MA 02631		102-40-0		50 FLYING MIST LANE			
TRANSFER HISTORY		DOS	T	SALE PRICE		BK-PG (Certs)	
VILLANDRY DAVID J & CHERY		02/12/2021	F	1 33788-177			
VILLANDRY DAVID J & CHERY		03/01/1985	XX	4435-183			

LAND

CD	T	AC/SF/UN	Nbhd	St Ind	Infl	ADJ BASE	SAF	Topo	Lpi	VC	CREDIT AMT	ADJ VALUE									
100	S	10,900	7	1.00	A	1.00	A	1.00	416,480	3.71	A	1.00	R09	1.90							387,050

TOTAL	10,900 SF	ZONING	RM	FRNT	0	ASSESSED	CURRENT	PREVIOUS
Nbhd	NBHD 7	NOTE	LAND	387,100	365,200			
St Ind	AVERAGE		BUILDING	559,400	534,600			
Infl	AVERAGE		DETACHED	1,100	1,000			
			OTHER	0	0			
TOTAL				947,600	900,800			

DETAILED

TY	QUAL	COND	DIM/NOTE	YB	UNITS	ADJ PRICE	RCNLD
SHF	A	1.00	50 0.50	8X12		22.01	1,100

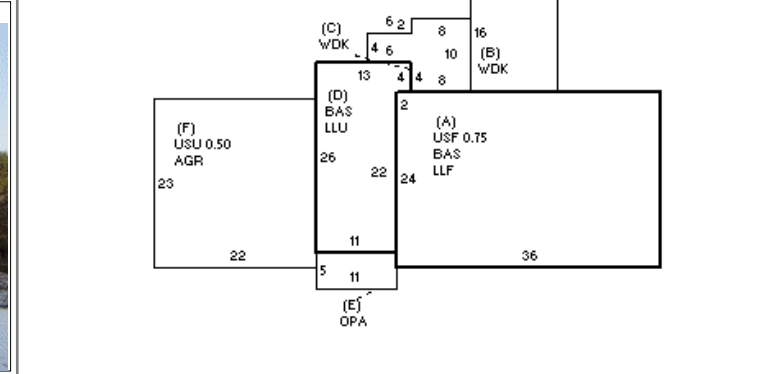

BUILDING

BUILDING	CD	ADJ	DESC	MEASURE	2/16/2017	NF
MODEL	1		RESIDENTIAL	LIST	4/4/2017	NF
STYLE	4	1.02	CAPE [100%]	REVIEW	2/16/2022	JMG
QUALITY	A	1.00	AVG [100%]			
FRAME	1	1.00	WD FRAME [100%]			

BLDG COMMENTS

GENERATOR
BSMT=BATH,FR,BR,KIT

G

YEAR BLT	1985	SIZE ADJ	0.990
NET AREA	2,670	DETAIL ADJ	1.000
\$NLA(RCN)	\$247	OVERALL	1.070

CAPACITY	UNITS	ADJ
STORIES	1.75	1.00
ROOMS	8	1.00
BEDROOMS	5	1.00
BATHROOMS	3	1.00
FIXTURES	10	\$13,910
GARAGE SPACES	0	1.00
% BSMT FIN	75	1.00
# 1/2 BATHS	0	1.00
# OF UNITS	1	1.00

ELEMENT	CD	DESCRIPTION	ADJ	S	BAT	T	DESCRIPTION	UNITS	YB	ADJ PRICE	RCN
FOUNDATION	4	FLR & WALL	1.00	A	LLF	L	LOWER LEVEL FIN	864	1985	134.88	116,539
EXT COVER	2	CLAPBOARD	1.00	A	BAS	L	BASE AREA	864	1985	268.95	232,373
ROOF SHAPE	1	GABLE	1.00	A	USF	L	UPPER STORY FIN	648	1985	194.75	126,199
ROOF COVER	1	ASPH/CMP SH	1.00	+	WDK	N	WOOD DECK	296		41.52	12,291
FLOOR COVER	1	HARDWOOD	1.00	D	LLU	N	LOWER LEVEL UNF	294		97.88	28,777
INT FINISH	2	DRYWALL	1.00	D	BAS	L	BASE AREA	294	2015	268.95	79,071
HEATING/COOL	11	HTWT/CL AIR	1.05	E	OPA	N	OPEN PORCH	55		52.97	2,913
FUEL SOURCE	2	GAS	1.00	F	AGR	N	ATT GARAGE	506		41.09	20,792
				F	USU	N	UPPER STORY UNF	253		59.78	15,124
					KIT	O	XTRA KITCHEN	1		2,298.70	2,299
					MST	O	MAS/METAL STACK	1		5,325.10	5,325
					ODS	O	OUTDOOR SHOWER	1		2,558.20	2,558

TOTAL RCN	658,171
CONDITION ELEM	CD
EXTERIOR	G
INTERIOR	G
KITCHEN	V
BATHS	A
HEAT/ELEC	A
EFF.YR/AGE	2003 / 20
COND	15 15 %
FUNC	0
ECON	0
DEPR	15 % GD 85
RCNLD	\$559,400