

Key: 1281

Town of BREWSTER - Fiscal Year 2025

9/17/2024 2:15 pm SEQ #: 1.393

LEG
AL
LAND

CURRENT OWNER				PARCEL ID				LOCATION					
LARSEN JEFFREY R & SHAWN Z 145 BROAD MEADOW ROAD NEEDHAM, MA 02492				102-41-0				40 FLYING MIST LANE					
TRANSFER HISTORY				DOS	T	SALE PRICE	BK-PG (Cert)						
LARSEN JEFFREY R & SHAWN				07/26/2018	QS	825,000	31427-133						
TOLIKAS MARY &				04/18/2012	QS	700,000	26256-96						
RUTLEDGE SARA R TRUSTEE				06/05/2003	N	220,000	17038-318						
CD	T	AC/SF/UN	Nbhd	St Ind	Infl	ADJ BASE	SAF	Topo	Lpi	VC	CREDIT AMT	ADJ VALUE	
100	S	11,500 7	1.00	A	1.00	A	1.00	416,480	3.55	A	1.00	R09 1.90	389,790

CLASS	CLASS%	DESCRIPTION			BN ID	BN	CARD	
1010	100	SINGLE FAMILY				1	1 of 1	
PMT NO	PMT DT	TY	DESC	AMOUNT	INSP	BY	1st	%
703	08/01/2019	14	CYCLICAL GRO		01/22/2021	NF	100	100
	07/26/2018	7	ALTERATIONS	2,000	07/13/2020	NF	100	100
	07/26/2018	16	MLS REVIEW	825,000	05/01/2019	JMG	100	100
463	07/30/2004	1	NEW CONSTRUCT	210,000	05/18/2005	JB	100	100

LAND

TOTAL	11,500 SF	ZONING	RM	FRNT	0	ASSESSED	CURRENT	PREVIOUS
Nbhd	NBHD 7	NOTE				LAND	389,800	367,700
St Ind	AVERAGE		BUILDING	875,300	835,700			
Infl	AVERAGE		DETACHED	0	0			
			OTHER	0	0			
						TOTAL	1,265,100	1,203,400

DETACHED

TY	QUAL	COND	DIM/NOTE	YB	UNITS	ADJ PRICE	RCNLD

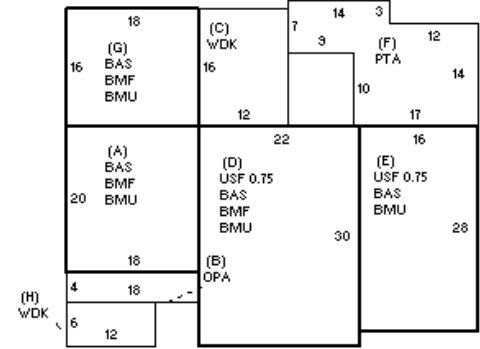

BUILDING

BUILDING	CD	ADJ	DESC	MEASURE	1/22/2021	NF
MODEL	1		RESIDENTIAL	LIST	1/22/2021	EST
STYLE	4	1.02	CAPE [100%]	REVIEW	3/1/2021	MR
QUALITY	G	1.30	GOOD [100%]			
FRAME	1	1.00	WD FRAME [100%]			

BLDG COMMENTS

BLDG

YEAR BLT	2004	SIZE ADJ	0.990	ELEMENT	CD	DESCRIPTION	ADJ	S	BAT	T	DESCRIPTION	UNITS	YB	ADJ PRICE	RCN	TOTAL RCN	983,453				
NET AREA	2,587	DETAIL ADJ	1.000	FOUNDATION	4	FLR & WALL	1.00	+	BMU	N	BSMT UNFINISHED	1,756		67.81	119,073	CONDITION ELEM	CD				
\$NLA(RCN)	\$380	OVERALL	1.030	EXT COVER	1	WD SHINGLE	1.00	+	BMF	N	BSMT FINISH	1,308		43.46	56,850	EXTERIOR	A				
				ROOF SHAPE	1	GABLE	1.00	A	BAS	L	BASE AREA	360	2004	313.69	112,929	INTERIOR	G				
				ROOF COVER	1	ASPH/CMP SH	1.00	B	OPA	N	OPEN PORCH	72		66.28	4,772	KITCHEN	G				
				FLOOR COVER	1	HARDWOOD	1.00	+	WDK	N	WOOD DECK	264		51.96	13,719	BATHS	A				
				INT FINISH	2	DRYWALL	1.00	+	BAS	L	BASE AREA	1,108	2004	313.69	347,571	HEAT/ELEC	A				
				HEATING/COOL	15	HTWT+DCTLS AC	1.01	+	USF	L	UPPER STORY FIN	831	2004	241.22	200,457						
				FUEL SOURCE	2	GAS	1.00	F	PTA	N	PATIO	316		17.92	5,662						
												G	BAS	L	BASE AREA	288	2004	313.69	90,343		
												GFP	O	GAS FIREPLACE	2		4,143.20	8,286			
												MST	O	MAS/METAL STACK	1		6,663.80	6,664			
												ODS	O	OUTDOOR SHOWER	1		3,201.30	3,201			
												EFF.YR/AGE		2011 / 12		COND	11 11 %				
														FUNC	0						
														ECON	0						
														DEPR	11 % GD	89					
												RCNLD				\$875,300					