

Key: 12835

Town of BREWSTER - Fiscal Year 2025

9/17/2024 2:15 pm SEQ #: 9.183

LEGAL

LAND

CURRENT OWNER				PARCEL ID				LOCATION			
GOYETTE DAVID M & SUZANNE 12 RIFFLES LANE HUDSON, MA 01749				98-13-0				35 CAPTAINS VILLAGE LANE			
TRANSFER HISTORY				DOS	T	SALE PRICE	BK-PG (Cert)				
GOYETTE DAVID M & SUZANNE				08/12/2020	QS	1,300,000	33160-24				
BARRETT ROBERTA TRUSTEE &				12/11/2013	QS	1,037,500	27877-16				
KATZENBERG RICHARD P &				05/03/2011	F	1	25422-179				

CLASS	CLASS%	DESCRIPTION			BN ID	BN	CARD	
1010	100	SINGLE FAMILY				1	1 of 1	
PMT NO	PMT DT	TY	DESC	AMOUNT	INSP	BY	1st	%
	08/12/2020	15	SALE REVIEW	1,300,000	03/01/2021	JMG	100	100
27	01/12/2015	7	ALTERATIONS	15,000	04/20/2016	WFF	100	100
446	05/29/2014	7	ALTERATIONS	5,000	06/09/2015	MW	100	100
		12	CYCLICAL NON		05/21/2013	SF	100	100
381	09/14/2009	10	INGROUND POO	55,000	04/23/2010	JH	100	100

CD	T	AC/SF/UN	Nbhd	St Ind	Infl	ADJ BASE	SAF	Topo	Lpi	VC	CREDIT AMT	ADJ VALUE				
100	S	60,000	13	1.00	13P	1.00	A	1.00	372,640	1.00	A	1.00	R13	1.70		515,690
300	A	0.471	13	1.00	13P	1.00	A	1.00	20,400	1.00	A	1.00	R13	1.70		9,610

TOTAL	1.848 Acres	ZONING	RL	FRNT	0	ASSESSED	CURRENT	PREVIOUS
Nbhd	NBHD 13	SUBDIV OF LOTS 18, 18-2, 18-3 & 93 FOR FY 2001 LOT15 ON PLAN BOOK 552/23,24,& 25	N O T E	LAND		525,300	495,600	
St Ind	CAPTAINS VILLAG			BUILDING		1,256,300	1,199,500	
Infl	AVERAGE			DETACHED		15,200	15,000	
				OTHER		0	0	
				<b>TOTAL</b>		<b>1,796,800</b>	<b>1,710,100</b>	

TY	QUAL	COND	DIM/NOTE	YB	UNITS	ADJ PRICE	RCNLD
PTD	A	1.00	20 0.80	34X12	408	7.20	2,400
HTB	A	1.00	20 0.80		1	4,058.10	3,200
DGF	A	1.00	10 0.90	14X24	336	31.80	9,600

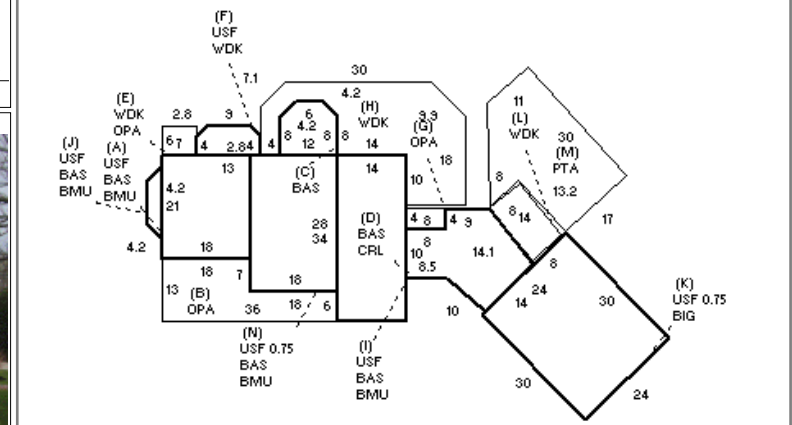

BUILDING	CD	ADJ	DESC	MEASURE	1/13/2021	TCK
MODEL	1		RESIDENTIAL	LIST	1/13/2021	EST
STYLE	4	1.02	CAPE [100%]	REVIEW	3/1/2021	JMG
QUALITY	G+	1.45	GOOD + [100%]			
FRAME	1	1.00	WD FRAME [100%]			

BLDG COMMENTS

DETACHED

BUILDING

YEAR BLT	2002	SIZE ADJ	0.970	ELEMENT	CD	DESCRIPTION	ADJ	S	BAT	T	DESCRIPTION	UNITS	YB	ADJ PRICE	RCN	TOTAL RCN	1,365,590		
NET AREA	3,725	DETAIL ADJ	1.000	FOUNDATION	4	FLR & WALL	1.00	+	BMU	N	BSMT UNFINISHED	1,394		80.25	111,868				
\$NLA(RCN)	\$367	OVERALL	1.050	EXT COVER	1	WD SHINGLE	1.00	+	USF	L	UPPER STORY FIN	1,882	2002	227.18	427,559				
				ROOF SHAPE	1	GABLE	1.00	+	OPA	N	OPEN PORCH	416		73.84	30,718				
				ROOF COVER	1	ASPH/CMP SH	1.00	+	BAS	L	BASE AREA	1,843	2002	342.20	630,666				
				FLOOR COVER	2	SOFTWOOD	1.00	D	CRL	N	BSMT CRAWL	326		44.84	14,619				
				INT FINISH	2	DRYWALL	1.00	+	WDK	N	WOOD DECK	815		57.89	47,182				
				HEATING/COOL	9	WARM/CL AIR	1.03	K	BIG	N	BUILT-IN GARAGE	720		70.24	50,569				
				FUEL SOURCE	2	GAS	1.00	M	PTA	N	PATIO	526		17.61	9,264				
												GFP	O	GAS FIREPLACE	3	4,616.07	13,848		
												ODS	O	OUTDOOR SHOWER	1	3,566.50	3,567		

CONDITION ELEM	CD
EXTERIOR	A
INTERIOR	G
KITCHEN	V
BATHS	G
HEAT/ELEC	A

EFF.YR/AGE	2015 / 8
COND	8 8 %
FUNC	0
ECON	0
DEPR	8 % GD 92

RCNLD	\$1,256,300
-------	-------------