

Key: 13067

Town of BREWSTER - Fiscal Year 2025

9/17/2024 2:15 pm SEQ #: 9.207

LEGAL

LAND

CURRENT OWNER				PARCEL ID				LOCATION					
BASSETT BRADFORD A & BASSETT PATRICIA A 924 GREAT FIELDS ROAD BREWSTER, MA 02631				52-160-0				924 GREAT FIELDS ROAD					
				TRANSFER HISTORY				DOS	T	SALE PRICE	BK-PG (Cert)		
				BASSETT BRADFORD A & BREWSTER TOWN OF				06/13/2000	N	100	13069-152		
				10/05/1995	N		928-129						

CLASS	CLASS%	DESCRIPTION			BN ID	BN	CARD	
1010	100	SINGLE FAMILY				1	1 of 1	
PMT NO	PMT DT	TY	DESC	AMOUNT	INSP	BY	1st	%
23-698	06/16/2023	2	ADD	170,000	05/30/2024	TCK	50	100
912	11/04/2014	3	OUT BUILDING	1,500	06/02/2015	MW	100	100
1063	12/11/2013	7	ALTERATIONS	19,700	08/21/2014	RJM	100	100
856	10/02/2013	7	ALTERATIONS	3,500	08/21/2014	RJM	100	100
663	08/15/2013	2	ADD	5,000	08/21/2014	RJM	100	100

CD	T	AC/SF/UN	Nbhd	St Ind	Infl	ADJ BASE	SAF	Topo	Lpi	VC	CREDIT AMT	ADJ VALUE				
100	S	60,000	14	1.00	A	1.00	A	1.00	197,280	1.00	A	1.00	RM3	0.90		273,010
300	A	0.046	14	1.00	A	1.00	A	1.00	10,800	1.00	A	1.00	RM3	0.90		500

TOTAL	1.423 Acres		ZONING	RL	FRNT	0		ASSESSED	CURRENT	PREVIOUS
Nbhd	NBHD 14		N O T E	SUBDIV OF PARCEL 27-1 FOR F/Y 2002 -- LOT 2 ON PLAN BOOK 557/31				LAND	143,530	135,400
St Ind	AVERAGE			BUILDING	225,450	167,200				
Infl	AVERAGE			DETACHED	2,890	2,830				
				OTHER	0	0				
				TOTAL	371,870	305,430				

TY	QUAL	COND	DIM/NOTE	YB	UNITS	ADJ PRICE	RCNLD
SHF	A	1.00	10 0.90 12X16	2011	192	20.77	3,600
SHF	A	1.00	10 0.90 8X12	2014	96	22.01	1,900



BLDG COMMENTS
WALKOUT BASEMENT ---- SOLAR PANELS

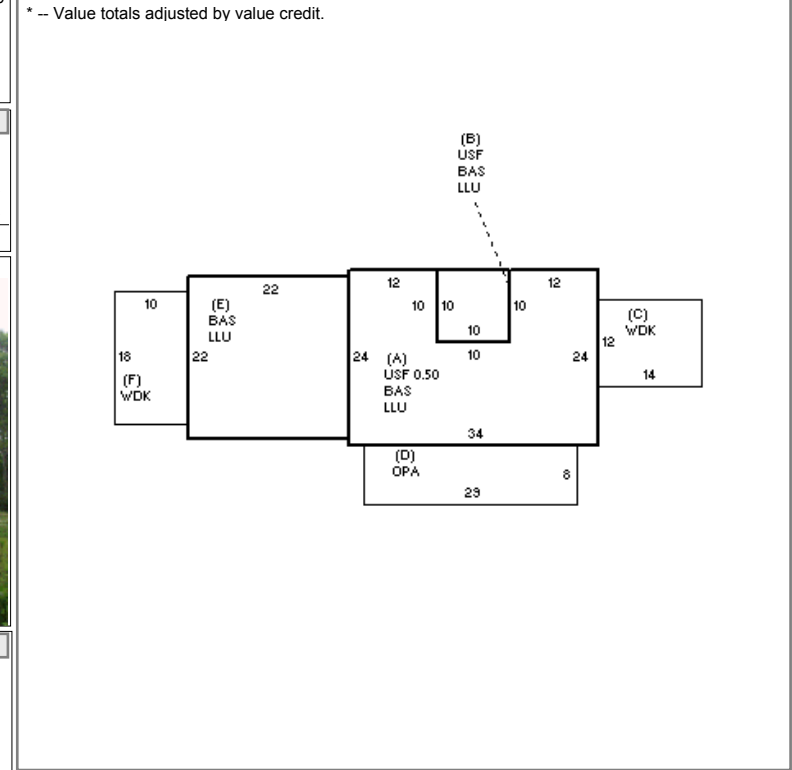

DETACHED

BUILDING

BUILDING	CD	ADJ	DESC	MEASURE	11/27/2007	REO
MODEL	1		RESIDENTIAL	LIST	11/27/2007	REO
STYLE	4	1.02	CAPE [100%]	REVIEW	6/12/2024	EMZ
QUALITY	A	1.00	AVG [100%]			
FRAME	1	1.00	WD FRAME [100%]			

YEAR BLT	2001	SIZE ADJ	1.000	ELEMENT	CD	DESCRIPTION	ADJ	S	BAT	T	DESCRIPTION	UNITS	YB	ADJ PRICE	RCN
NET AREA	1,758	DETAIL ADJ	1.000	FOUNDATION	4	FLR & WALL	1.00	+	LLU	N	LOWER LEVEL UNF	1,300		82.39	107,107
\$NLA(RCN)	\$330	OVERALL	1.070	EXT COVER	1	WD SHINGLE	1.00	+	BAS	L	BASE AREA	816	2001	263.76	215,224
				ROOF SHAPE	1	GABLE	1.00	+	USF	L	UPPER STORY FIN	458	2001	198.73	91,016
				ROOF COVER	1	ASPH/CMP SH	1.00	+	WDK	N	WOOD DECK	348		41.95	14,597
				FLOOR COVER	2	SOFTWOOD	1.00	D	OPA	N	OPEN PORCH	232		53.50	12,412
				INT FINISH	2	DRYWALL	1.00	E	BAS	L	BASE AREA	484	2023	263.75	127,657
				HEATING/COOL	11	HTWT/CL AIR	1.05								
				FUEL SOURCE	2	GAS	1.00								

TOTAL RCN	580,533	
CONDITION ELEM	CD	
EXTERIOR	G	
INTERIOR	A	
KITCHEN	A	
BATHS	A	
HEAT/ELEC	A	
EFF.YR/AGE	2011 / 12	
COND	11 11 %	
FUNC	15 UC	
ECON	0 AFFORDABLE	
DEPR	26 % GD	74
RCNLD	\$429,600	