

Key: 1401

Town of BREWSTER - Fiscal Year 2025

9/17/2024 2:15 pm SEQ #: 1.517

LEGAL

LAND

DETACHED

BUILDING

ILLDING

CURRENT OWNER		PARCEL ID	LOCATION			
BALBONI DAVID P & JEAN O P O BOX 2294 BREWSTER, MA 02631		90-23-0	123 WINSLOW LANDING ROAD			
TRANSFER HISTORY		DOS	T	SALE PRICE	BK-PG (Cert)	
BALBONI DAVID P & JEAN O		04/16/2013	F		1 27291-113	
BALBONI DAVID P & JEAN O		07/30/1976	XX		2377-124	

CLASS	CLASS%	DESCRIPTION			BN ID	BN	CARD	
1010	100	SINGLE FAMILY				1	1 of 1	
PMT NO	PMT DT	TY	DESC	AMOUNT	INSP	BY	1st	%
596	08/09/2012	7	ALTERATIONS	21,000	02/01/2013	MR	100	100
172	03/14/2012	1	NEW CONSTRUC	400,000	02/01/2013	MR	100	100

CD	T	AC/SF/UN	Nbhd	St Ind	Infl	ADJ BASE	SAF	Topo	Lpi	VC	CREDIT AMT	ADJ VALUE	
100	S	19,396 6	1.00	A	1.00	A	1.00	767,200	2.27	A	1.00	R12 3.50	775,660

TOTAL	19,396 SF	ZONING	RM	FRNT	0	ASSESSED	CURRENT	PREVIOUS
Nbhd	NBHD 6	NOTE	LAND	775,700	585,400			
St Ind	AVERAGE		BUILDING	1,003,100	957,700			
Infl	AVERAGE		DETACHED	600	600			
			OTHER	0	0			
			TOTAL	1,779,400	1,543,700			

TY	QUAL	COND	DIM/NOTE	YB	UNITS	ADJ PRICE	RCNLD
PTD	A	1.00	10 0.90 10X6	2012	60	11.70	600



BLDG COMMENTS	INFO @ DOOR (12/4/20)
---------------	-----------------------

BUILDING	CD	ADJ	DESC	MEASURE	12/4/2020	NF
MODEL	1		RESIDENTIAL	LIST	2/1/2013	MR
STYLE	4	1.02	CAPE [100%]	REVIEW	1/12/2021	MR
QUALITY	G	1.30	GOOD [100%]			
FRAME	1	1.00	WD FRAME [100%]			

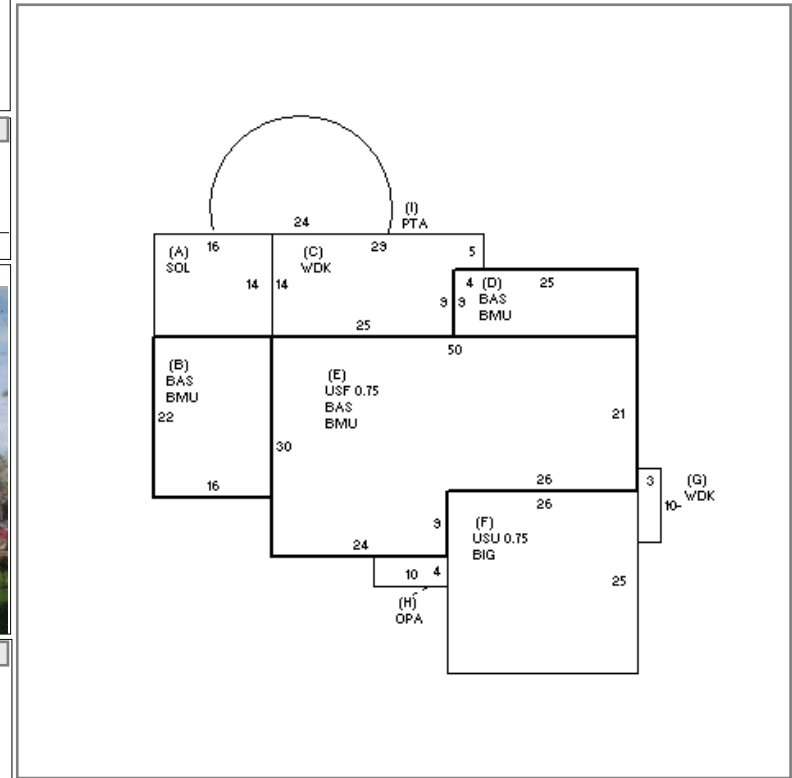

YEAR BLT	2012	SIZE ADJ	0.990
NET AREA	2,793	DETAIL ADJ	1.000
\$NLA(RCN)	\$399	OVERALL	1.050
CAPACITY		UNITS	ADJ
STORIES	1.75	1.00	
ROOMS	8	1.00	
BEDROOMS	4	1.00	
BATHROOMS	2	1.00	
FIXTURES	10	\$17,745	
GARAGE SPACES	2	1.00	
% BSMT FIN	0	1.00	
# 1/2 BATHS	1	1.00	
# OF UNITS	1	1.00	

ELEMENT	CD	DESCRIPTION	ADJ
FOUNDATION	4	FLR & WALL	1.00
EXT COVER	1	WD SHINGLE	1.00
ROOF SHAPE	1	GABLE	1.00
ROOF COVER	1	ASPH/CMP SH	1.00
FLOOR COVER	1	HARDWOOD	1.00
INT FINISH	2	DRYWALL	1.00
HEATING/COOL	9	WARM/CL AIR	1.03
FUEL SOURCE	2	GAS	1.00

S	BAT	T	DESCRIPTION	UNITS	YB	ADJ PRICE	RCN
A	SOL	N	SOLARIUM	224		156.89	35,143
+	BMU	N	BSMT UNFINISHED	1,843		67.37	124,166
+	BAS	L	BASE AREA	1,843	2012	313.12	577,083
+	WDK	N	WOOD DECK	400		52.97	21,189
E	USF	L	UPPER STORY FIN	950	2012	245.91	233,612
F	BIG	N	BUILT-IN GARAGE	650		64.27	41,774
F	USU	N	UPPER STORY UNF	488		76.26	37,214
H	OPA	N	OPEN PORCH	40		67.57	2,703
I	PTA	N	PATIO	332		18.26	6,064
	F11	O	FPL 1S 1OP	1		10,320.30	10,320
	GFP	O	GAS FIREPLACE	1		4,224.30	4,224
	ODS	O	OUTDOOR SHOWER	1		3,263.50	3,264

TOTAL RCN	1,114,501
CONDITION ELEM	CD
EXTERIOR	A
INTERIOR	A
KITCHEN	A
BATHS	A
HEAT/ELEC	A
EFF.YR/AGE	2012 / 11
COND	11 11 %
FUNC	0
ECON	0
DEPR	10 % GD 90
RCNLD	\$1,003,100