

Key: 14087

Town of BREWSTER - Fiscal Year 2025

9/17/2024 2:15 pm SEQ #: 9.380

LEGALS

| CURRENT OWNER  |  |  |  | PARCEL ID  |    |            |              | LOCATION         |  |  |  |
|--|--|--|--|------------|----|------------|--------------|------------------|--|--|--|
| BREWSTER TOWN OF<br>(EDDY ELEMENTARY SCHOOL)<br>2298 MAIN STREET<br>BREWSTER, MA 02631 |  |  |  | 77-58-0    |    |            |              | 2298 MAIN STREET |  |  |  |
| TRANSFER HISTORY   |  |  |  | DOS        | T  | SALE PRICE | BK-PG (Cert) |                  |  |  |  |
| BREWSTER TOWN OF   |  |  |  | 08/27/1975 | XX |            | 2227-223     |                  |  |  |  |

| CLASS  | CLASS%     | DESCRIPTION    |              |           | BN ID      | BN  | CARD   |     |
|--------|------------|----------------|--------------|-----------|------------|-----|--------|-----|
| 9340   | 100        | IMP. EDUCATION |              |           |            | 1   | 1 of 2 |     |
| PMT NO | PMT DT     | TY             | DESC         | AMOUNT    | INSP       | BY  | 1st    | %   |
| 587    | 07/07/2016 | 7              | ALTERATIONS  | 4,000     | 05/18/2017 | RJM | 100    | 100 |
| 504    | 06/24/2014 | 7              | ALTERATIONS  | 16,500    | 07/07/2015 | RJM | 100    | 100 |
| 503    | 06/24/2014 | 7              | ALTERATIONS  | 2,937,700 | 07/07/2015 | RJM | 100    | 100 |
| 496    | 06/19/2014 | 7              | ALTERATIONS  | 3,500     | 07/07/2015 | RJM | 100    | 100 |
| 480    | 11/17/2009 | 77             | SOLAR PANELS | 157,443   | 05/05/2010 | JH  | 100    | 100 |

LAND

| CD  | T | AC/SF/UN | Nbhd | St Ind | Infl | ADJ BASE | SAF  | Topo | Lpi     | VC   | CREDIT AMT | ADJ VALUE |     |      |  |         |
|-----|---|----------|------|--------|------|----------|------|------|---------|------|------------|-----------|-----|------|--|---------|
| 103 | S | 60,000   | CIM  | 1.00   | 37   | 1.00     | A    | 1.00 | 322,400 | 1.00 | A          | 1.00      | C02 | 1.00 |  | 444,080 |
| 203 | A | 1.377    | CIM  | 1.00   | 37   | 1.00     | A    | 1.00 | 142,900 | 1.00 | A          | 1.00      | C02 | 1.00 |  | 196,770 |
| 303 | A | 21,966   | CIM  | 1.00   | 37   | 1.00     | A    | 1.00 | 14,200  | 1.00 | A          | 1.00      | C02 | 1.00 |  | 311,920 |
| 350 | A | 3.930    |      | 10     | 1.00 | 37       | 1.00 | A    | 1.00    |      | TWP        | 1.00      |     |      |  | 8,250   |

\* -- Partial Listing. See Next Page.

|        |               |                  |   |           |           |            |            |          |
|--------|---------------|------------------|---|-----------|-----------|------------|------------|----------|
| TOTAL  | 28.650 Acres  | ZONING           | CH  | FRNT      | 0         | ASSESSED   | CURRENT    | PREVIOUS |
| Nbhd   | CIM           | N<br>O<br>T<br>E | Division of M16 Parcel 80 for F/Y 08 -- Lot 1 on Plan Book 613/30 |           |           | LAND       | 961,000    | 925,000  |
| St Ind | PAINES-SACHEM |                  | BUILDING  | 9,496,100 | 9,150,400 |            |            |          |
| Infl   | AVERAGE       |                  | DETACHED  | 170,300   | 170,100   |            |            |          |
|        |               |                  | OTHER   | 0         | 0         |            |            |          |
|        |               |                  |   |           | TOTAL     | 10,627,400 | 10,245,500 |          |

DETAILED

| TY  | QUAL | COND | DIM/NOTE | YB      | UNITS  | ADJ PRICE | RCNLD  |
|-----|------|------|----------|---------|--------|-----------|--------|
| PAV | A    | 1.00 | 50 0.50  |         | 80,000 | 2.20      | 88,000 |
| PAV | A    | 1.00 | 10 0.90  |         | 40,000 | 2.20      | 79,200 |
| SHF | -    | 0.90 | 50 0.50  | 10 X 20 | 2004   | 200       | 18.69  |
| SHF | -    | 0.90 | 50 0.50  | 10 X 12 | 2008   | 120       | 19.25  |

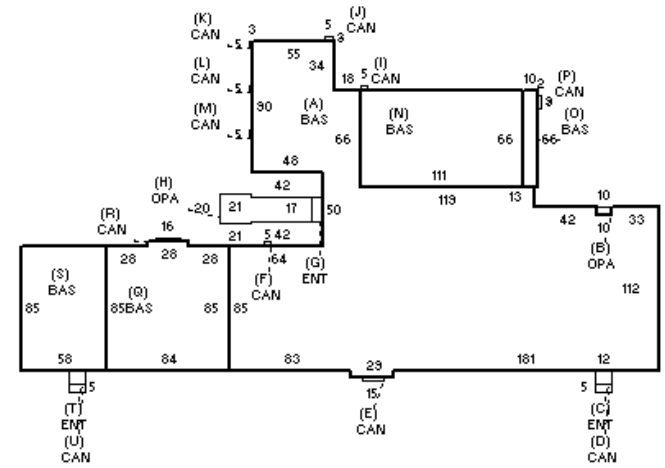

BUILDING

| BUILDING | CD | ADJ  | DESC             | MEASURE | 12/28/2022 | JMG |
|----------|----|------|------------------|---------|------------|-----|
| MODEL    | 5  |      | CIM              | LIST    | 1/1/1997   | BC  |
| STYLE    | 96 | 1.75 | SCHOOLS [100%]   | REVIEW  | 12/28/2022 | JMG |
| QUALITY  | E  | 1.50 | EXCELLENT [100%] |         |            |     |
| FRAME    | 2  | 1.00 | MASONRY [100%]   |         |            |     |

BLDG COMMENTS  
EDDY ELEMENTARY SCHOOL/SOLAR PANELS

INDING

| YEAR BLT   | 1996   | SIZE ADJ   | 0.813 | ELEMENT      | CD | DESCRIPTION    | ADJ  | S | BAT | T | DESCRIPTION * | UNITS  | YB   | ADJ PRICE | RCN       | TOTAL RCN      | 11,304,850 |
|------------|--------|------------|-------|--------------|----|----------------|------|---|-----|---|---------------|--------|------|-----------|-----------|----------------|------------|
| NET AREA   | 59,364 | DETAIL ADJ | 1.820 | FOUNDATION   | 2  | SLAB           | 1.00 | A | BAS | L | BASE AREA     | 39,224 | 1996 | 188.78    | 7,404,831 |                |            |
| \$NLA(RCN) | \$190  | OVERALL    | 1.015 | EXT. COVER   | 1  | WOOD SHINGLE   | 1.00 | + | OPA | N | OPEN PORCH    | 1,194  |      | 47.53     | 56,755    | CONDITION ELEM | CD         |
|            |        |            |       | ROOF SHAPE   | 1  | GABLE          | 1.00 | + | ENT | N | ENCL ENTRY    | 352    |      | 45.08     | 15,867    | EXTERIOR       | G          |
|            |        |            |       | ROOF COVER   | 1  | ASPH/CMP SHNGL | 1.00 | D | CAN | N | CANOPY        | 60     |      | 38.08     | 2,285     | INTERIOR       | G          |
|            |        |            |       | FLOOR COVER  | 5  | VINYL          | 1.00 | E | CAN | N | CANOPY        | 45     |      | 38.07     | 1,713     |                |            |
|            |        |            |       | INT. FINISH  | 5  | OTHER          | 1.00 | F | CAN | N | CANOPY        | 15     |      | 38.09     | 571       |                |            |
|            |        |            |       | HEATING/COOL | 9  | WARM/COOL AIR  | 1.00 | I | CAN | N | CANOPY        | 15     |      | 38.09     | 571       |                |            |
|            |        |            |       | FUEL SOURCE  | 2  | GAS            | 1.00 | J | CAN | N | CANOPY        | 15     |      | 38.09     | 571       |                |            |
|            |        |            |       |              |    |                |      | K | CAN | N | CANOPY        | 15     |      | 38.09     | 571       |                |            |
|            |        |            |       |              |    |                |      | L | CAN | N | CANOPY        | 15     |      | 38.09     | 571       |                |            |
|            |        |            |       |              |    |                |      | M | CAN | N | CANOPY        | 15     |      | 38.09     | 571       |                |            |
|            |        |            |       |              |    |                |      | N | BAS | L | BASE AREA     | 7,326  | 1996 | 188.78    | 1,383,026 | EFF.YR/AGE     | 2007 / 16  |
|            |        |            |       |              |    |                |      | O | BAS | L | BASE AREA     | 660    | 1996 | 188.78    | 124,597   | COND           | 16 16 %    |
|            |        |            |       |              |    |                |      | P | CAN | N | CANOPY        | 18     |      | 38.06     | 685       | FUNC           | 0          |
|            |        |            |       |              |    |                |      | Q | BAS | L | BASE AREA     | 7,224  | 1996 | 188.78    | 1,363,769 | ECON           | 0          |
|            |        |            |       |              |    |                |      | R | CAN | N | CANOPY        | 48     |      | 38.06     | 1,827     | DEPR           | 16 % GD 84 |
|            |        |            |       |              |    |                |      |   |     |   |               |        |      |           | RCNLD     | \$9,496,100    |            |

Key: 14087

Town of BREWSTER - Fiscal Year 2025

9/17/2024 2:15 pm SEQ #: 9.381

LEGAL

|  |  |  |  |                  |  |  |  |                  |   |            |              |
|--|--|--|--|------------------|--|--|--|------------------|---|------------|--------------|
| CURRENT OWNER  |  |  |  | PARCEL ID        |  |  |  | LOCATION         |   |            |              |
| BREWSTER TOWN OF<br>(EDDY ELEMENTARY SCHOOL)<br>2298 MAIN STREET<br>BREWSTER, MA 02631 |  |  |  | 77-58-0          |  |  |  | 2298 MAIN STREET |   |            |              |
|  |  |  |  | TRANSFER HISTORY |  |  |  | DOS              | T | SALE PRICE | BK-PG (Cert) |

|        |        |                |      |        |       |    |        |   |
|--------|--------|----------------|------|--------|-------|----|--------|---|
| CLASS  | CLASS% | DESCRIPTION    |      |        | BN ID | BN | CARD   |   |
| 9340   | 100    | IMP. EDUCATION |      |        |       | 1  | 2 of 2 |   |
| PMT NO | PMT DT | TY             | DESC | AMOUNT | INSP  | BY | 1st    | % |

LAND

|    |   |          |      |        |      |          |     |      |     |    |            |           |
|----|---|----------|------|--------|------|----------|-----|------|-----|----|------------|-----------|
| CD | T | AC/SF/UN | Nbhd | St Ind | Infl | ADJ BASE | SAF | Topo | Lpi | VC | CREDIT AMT | ADJ VALUE |
|----|---|----------|------|--------|------|----------|-----|------|-----|----|------------|-----------|

\* -- Partial Listing. See Previous Page.

DETACHED

|        |        |      |          |         |          |
|--------|--------|------|----------|---------|----------|
| TOTAL  | ZONING | FRNT | ASSESSED | CURRENT | PREVIOUS |
| Nbhd   | NOTE   |      | LAND     |         |          |
| St Ind |        |      | BUILDING |         |          |
| Infl   |        |      | DETACHED |         |          |
|        |        |      | OTHER    |         |          |
|        |        |      | TOTAL    |         |          |

|    |      |      |          |    |       |           |       |       |
|----|------|------|----------|----|-------|-----------|-------|-------|
| TY | QUAL | COND | DIM/NOTE | YB | UNITS | ADJ PRICE | RCNLD | PHOTO |
|----|------|------|----------|----|-------|-----------|-------|-------|

BUILDING

|          |    |     |      |         |
|----------|----|-----|------|---------|
| BUILDING | CD | ADJ | DESC | MEASURE |
| MODEL    |    |     |      | LIST    |
| STYLE    |    |     |      | REVIEW  |
| QUALITY  |    |     |      |         |
| FRAME    |    |     |      |         |

|            |            |         |    |             |     |   |     |   |               |       |      |           |         |                |
|------------|------------|---------|----|-------------|-----|---|-----|---|---------------|-------|------|-----------|---------|----------------|
| YEAR BLT   | SIZE ADJ   | ELEMENT | CD | DESCRIPTION | ADJ | S | BAT | T | DESCRIPTION * | UNITS | YB   | ADJ PRICE | RCN     | TOTAL RCN      |
| NET AREA   | DETAIL ADJ |         |    |             |     | S | BAS | L | BASE AREA     | 4,930 | 1996 | 188.78    | 930,701 | CONDITION ELEM |
| \$NLA(RCN) | OVERALL    |         |    |             |     | U | CAN | N | CANOPY        | 60    |      | 38.08     | 2,285   | CD             |
| CAPACITY   |            |         |    |             |     |   | CLR | N | COOLER        | 144   |      | 38.06     | 5,481   |                |
|            |            |         |    |             |     |   | FRZ | N | FREEZER       | 144   |      | 52.78     | 7,600   |                |

|             |      |
|-------------|------|
| EFF. YR/AGE |      |
| COND        |      |
| FUNC        |      |
| ECON        |      |
| DEPR        | % GD |
| RCNLD       |      |