

Key: 157

Town of BREWSTER - Fiscal Year 2025

9/17/2024 2:15 pm SEQ #: 167

LEGAL

LAND

DETACHED

BUILDING

CURRENT OWNER		PARCEL ID		LOCATION	
SMITH ANNE O TRUSTEE 130 MT AUBURN ST # 301 CAMBRIDGE, MA 02138		50-23-0		217 CEMETERY ROAD	
TRANSFER HISTORY		DOS	T	SALE PRICE	BK-PG (Cert)
SMITH ANNE O TRUSTEE		01/07/2003	F	1 16198-011	
SMITH ANNE OLIPHANT		03/18/1994	A	100 9100-325	

CLASS	CLASS%	DESCRIPTION		BN ID	BN	CARD	
1010	100	SINGLE FAMILY			1	1 of 1	
PMT NO	PMT DT	TY	DESC	AMOUNT	INSP	BY	1st %
593	06/25/2021	77	SOLAR PANELS	25,000	04/28/2022	TCK	100 100
125	04/14/2009	3	OUT BUILDING	6,000	04/08/2010	JH	100 100
67	02/04/2008	6	DEMO	9,000	09/29/2008	JH	100 100
790	11/30/2007	1	NEW CONSTRUCT	600,000	03/09/2009	JH	100 100

CD	T	AC/SF/UN	Nbhd	St Ind	Infl	ADJ BASE	SAF	Topo	Lpi	VC	CREDIT AMT	ADJ VALUE
100	S	14,072	3	1.00	A	1,468,640	2.97	A	1.00	BVG	6.70	1,410,900

TOTAL	14,072 SF	ZONING	RM	FRNT	0	ASSESSED	CURRENT	PREVIOUS
Nbhd	NBHD 3	NOTE				LAND	1,410,900	1,331,100
St Ind	AVERAGE		LAND	1,018,900	962,500			
Infl	AVERAGE		BUILDING	2,800	2,700			
			OTHER	0	0			
						TOTAL	2,432,600	2,296,300

TY	QUAL	COND	DIM/NOTE	YB	UNITS	ADJ PRICE	RCNLD
SHF	G	1.20	10 0.90	10X12	2009	120	25.67 2,800



BLDG COMMENTS  
PULL DOWN STAIRS TO ATTIC  
13 SOLAR PANELS

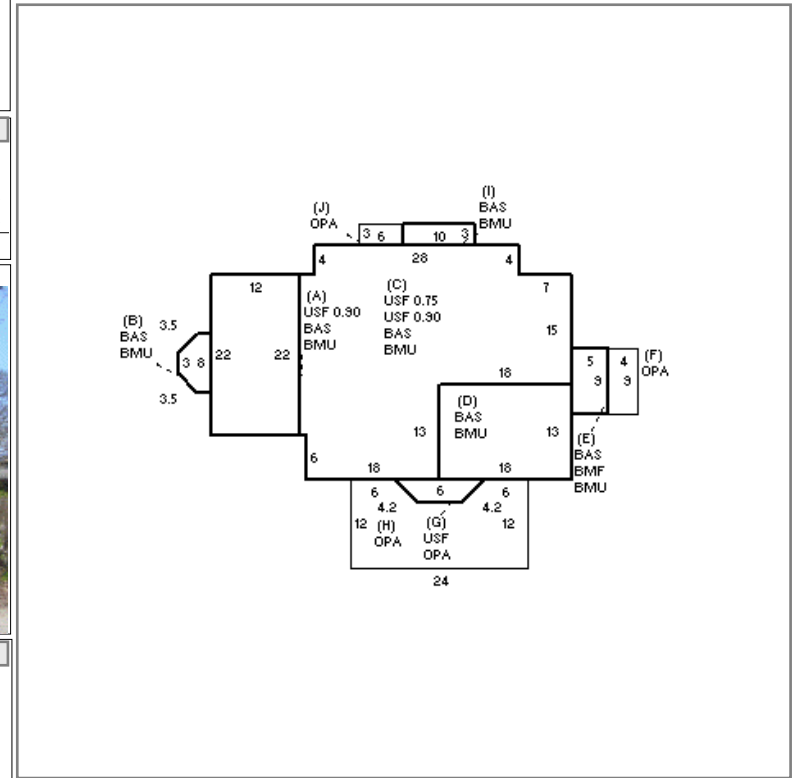

BUILDING	CD	ADJ	DESC	MEASURE	6/21/2018	NF
MODEL	1		RESIDENTIAL	LIST	6/21/2018	NF
STYLE	5	1.05	COLONIAL [100%]	REVIEW	5/20/2022	MR
QUALITY	G+	1.45	GOOD + [100%]			
FRAME	1	1.00	WD FRAME [100%]			

YEAR BLT	2007	SIZE ADJ	0.980	ELEMENT	CD	DESCRIPTION	ADJ	S	BAT	T	DESCRIPTION	UNITS	YB	ADJ PRICE	RCN
NET AREA	3,274	DETAIL ADJ	1.000	FOUNDATION	4	FLR & WALL	1.00	+	BMU	N	BSMT UNFINISHED	1,511		80.77	122,039
\$NLA(RCN)	\$358	OVERALL	1.080	EXT COVER	1	WD SHINGLE	1.00	+	BAS	L	BASE AREA	1,277	2007	370.73	473,426
				ROOF SHAPE	3	GAMBREL	1.00	+	USF	L	UPPER STORY FIN	1,763	2007	236.08	416,214
				ROOF COVER	1	ASPH/CMP SH	1.00	D	BAS	L	BASE AREA	234	2007	370.73	86,751
				FLOOR COVER	1	HARDWOOD	1.00	E	BMF	N	BSMT FINISH	45		61.90	2,785
				INT FINISH	2	DRYWALL	1.00	+	OPA	N	OPEN PORCH	342		76.73	26,243
				HEATING/COOL	9	WARM/CL AIR	1.03	F21	O	O	FPL 2S 1OP	1		15,578.50	15,579
				FUEL SOURCE	2	GAS	1.00	ODS	O	O	OUTDOOR SHOWER	1		3,706.30	3,706

TOTAL RCN	1,171,173
CONDITION ELEM	CD
EXTERIOR	A
INTERIOR	A
KITCHEN	A
BATHS	A
HEAT/ELEC	A
EFF.YR/AGE	2007 / 16
COND	13 13 %
FUNC	0
ECON	0
DEPR	13 % GD 87
RCNLD	\$1,018,900