

Key: 1610

Town of BREWSTER - Fiscal Year 2025

9/17/2024 2:15 pm SEQ #: 1.748

LEGALS

CURRENT OWNER				PARCEL ID				LOCATION			
MESSINA ROBERT 7126 ELM STREET FRISCO, TX 75034				78-66-0				28 FOSTER ROAD			
TRANSFER HISTORY				DOS	T	SALE PRICE	BK-PG (Cert)				
MESSINA ROBERT				11/14/2002	A	1	15916-058				
MESSINA ROBERT & DEBRA M				07/19/2001	A	1	14056-023				
LOPEZ DEBRA JANE TRUSTEE				10/02/1992	A	100	8233-162				

CLASS	CLASS%	DESCRIPTION			BN ID	BN	CARD	
1010	100	SINGLE FAMILY				1	1 of 1	
PMT NO	PMT DT	TY	DESC	AMOUNT	INSP	BY	1st	%
202	03/08/2019	7	ALTERATIONS	9,500	07/09/2020	NF	100	100
73	01/28/2019	7	ALTERATIONS	4,500	07/09/2020	NF	100	100
874	10/11/2018	7	ALTERATIONS	51,251	07/09/2020	NF	100	100
642	07/30/2018	7	ALTERATIONS	10,000	07/08/2019	NF	100	100
541	06/26/2018	7	ALTERATIONS	3,000	07/08/2019	NF	100	100

LAND

CD	T	AC/SF/UN	Nbhd	St Ind	Infl	ADJ BASE	SAF	Topo	Lpi	VC	CREDIT AMT	ADJ VALUE
100	S	12,305	5	1.00	5-A	1.00	A	1.00				393,300

TOTAL	12,305 SF	ZONING	RM	FRNT	0	ASSESSED	CURRENT	PREVIOUS
Nbhd	NBHD 5	NOTE				LAND	393,300	371,100
St Ind	CATHEDRAL RD		BUILDING	371,900	351,200			
Infl	AVERAGE		DETACHED	1,500	1,500			
			OTHER	0	0			
						TOTAL	766,700	723,800

DETACHED

TY	QUAL	COND	DIM/NOTE	YB	UNITS	ADJ PRICE	RCNLD	PHOTO	11/04/2020
SHF	A	1.00	30 0.70 8X12	1993	96	22.01	1,500		

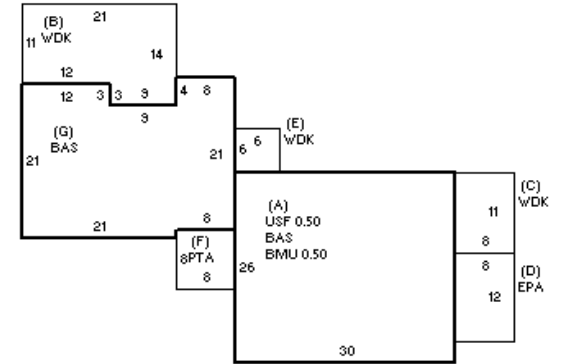

BUILDING

BUILDING	CD	ADJ	DESC	MEASURE	11/4/2020	NF
MODEL	1		RESIDENTIAL	LIST	11/4/2020	EST
STYLE	4	1.02	CAPE [100%]	REVIEW	1/5/2021	MR
QUALITY	A	1.00	AVG [100%]			
FRAME	1	1.00	WD FRAME [100%]			

BLDG COMMENTS

G

YEAR BLT	1930	SIZE ADJ	1.000	ELEMENT	CD	DESCRIPTION	ADJ	S	BAT	T	DESCRIPTION	UNITS	YB	ADJ PRICE	RCN	TOTAL RCN	489,381
NET AREA	1,752	DETAIL ADJ	1.000	FOUNDATION	4	FLR & WALL	1.00	A	BMU	N	BSMT UNFINISHED	390		68.18	26,591		
\$NLA(RCN)	\$279	OVERALL	1.020	EXT COVER	1	WD SHINGLE	1.00	A	USF	L	UPPER STORY FIN	390	1930	189.44	73,881		
				ROOF SHAPE	1	GABLE	1.00	+	WDK	N	WOOD DECK	382		39.98	15,274		
				ROOF COVER	1	ASPH/CMP SH	1.00	D	EPA	N	ENCLOSED PORCH	96		94.42	9,065		
				FLOOR COVER	3	W/W CARPET	1.00	F	PTA	N	PATIO	64		21.09	1,350		
				INT FINISH	2	DRYWALL	1.00	+	BAS	L	BASE AREA	1,362	1930	251.43	342,448		
				HEATING/COOL	2	HOT WATER	1.00	F21	O	FPL 2S 1OP	1			10,354.00	10,354		
				FUEL SOURCE	1	OIL	1.00	ODS	O	OUTDOOR SHOWER	1			2,463.30	2,463		
																RCNLD	\$371,900

CONDITION ELEM	CD
EXTERIOR	G
INTERIOR	E
KITCHEN	V
BATHS	V
HEAT/ELEC	A

EFF. YR/AGE	1985 / 38
COND	24 24 %
FUNC	0
ECON	0
DEPR	24 % GD 76