

Key: 1685

Town of BREWSTER - Fiscal Year 2025

9/17/2024 2:15 pm SEQ #: 1.817

LEGAL

CURRENT OWNER				PARCEL ID				LOCATION			
PESANELLI MARTINA M 126 BITTERSWEET DRIVE BREWSTER, MA 02631				79-83-0				126 BITTERSWEET DRIVE			
TRANSFER HISTORY				DOS	T	SALE PRICE	BK-PG (Cert)				
PESANELLI MARTINA M				02/01/2012	F		1 26047-119				
PESANELLI FELIX A & MARTI				09/11/1972	XX		1718-330				

CLASS	CLASS%	DESCRIPTION			BN ID	BN	CARD	
1010	100	SINGLE FAMILY				1	1 of 1	
PMT NO	PMT DT	TY	DESC	AMOUNT	INSP	BY	1st	%
700	08/26/2013	5	OTHER	700	08/06/2014	RJM	100	100

LAND

CD	T	AC/SF/UN	Nbhd	St Ind	Infl	ADJ BASE	SAF	Topo	Lpi	VC	CREDIT AMT	ADJ VALUE	
100	S	19,825 5	1.00	5-A	1.00	A	1.00	372,640	2.23	A	1.00	R07 1.70	378,030

TOTAL	19,825 SF	ZONING	RM	FRNT	0	ASSESSED	CURRENT	PREVIOUS
Nbhd	NBHD 5	NOTE				LAND	378,000	356,600
St Ind	CATHEDRAL RD		BUILDING	472,900	446,600			
Infl	AVERAGE		DETACHED	0	0			
			OTHER	0	0			
			TOTAL	850,900	803,200			

DETACHED

TY	QUAL	COND	DIM/NOTE	YB	UNITS	ADJ PRICE	RCNLD

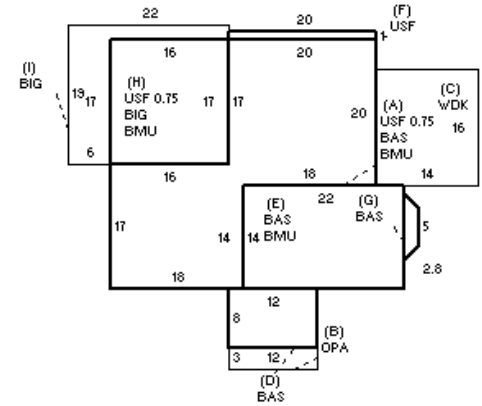

BLDG COMMENTS

BUILDING

BUILDING	CD	ADJ	DESC	MEASURE	11/13/2020	NF
MODEL	1		RESIDENTIAL	LIST	10/4/2007	REO
STYLE	4	1.02	CAPE [100%]	REVIEW	1/7/2021	MR
QUALITY	+	1.10	PLUS AVE [100%]			
FRAME	1	1.00	WD FRAME [100%]			

G

YEAR BLT	1985	SIZE ADJ	1.000	ELEMENT	CD	DESCRIPTION	ADJ	S	BAT	T	DESCRIPTION	UNITS	YB	ADJ PRICE	RCN	TOTAL RCN	606,298
NET AREA	1,867	DETAIL ADJ	1.000	FOUNDATION	4	FLR & WALL	1.00	+	BMU	N	BSMT UNFINISHED	1,280		60.97	78,040		
\$NLA(RCN)	\$325	OVERALL	1.020	EXT COVER	1	WD SHINGLE	1.00	B	OPA	N	OPEN PORCH	36		56.10	2,020		
				ROOF SHAPE	1	GABLE	1.00	C	WDK	N	WOOD DECK	224		43.98	9,852		
				ROOF COVER	1	ASPH/CMP SH	1.00	+	BAS	L	BASE AREA	810	1985	284.87	230,745		
				FLOOR COVER	3	W/W CARPET	1.00	E	BAS	L	BASE AREA	308	1985	284.87	87,740		
				INT FINISH	2	DRYWALL	1.00	+	USF	L	UPPER STORY FIN	749	1985	206.28	154,502		
				HEATING/COOL	2	HOT WATER	1.00	H	BIG	N	BUILT-IN GARAGE	272		62.05	16,877		
				FUEL SOURCE	1	OIL	1.00	I	BIG	N	BUILT-IN GARAGE	146		64.53	9,421		
						MST		O	MAS/METAL STACK			1		5,640.30	5,640		
						ODS		O	OUTDOOR SHOWER			1		2,709.60	2,710		
																EFF.YR/AGE	1989 / 34
																COND	22 22 %
																FUNC	0
																ECON	0
																DEPR	22 % GD 78
																RCNLD	\$472,900