

Key: 1754

Town of BREWSTER - Fiscal Year 2025

9/17/2024 2:15 pm SEQ #: 1.889

LEGALS

CURRENT OWNER				PARCEL ID				LOCATION			
ANDERSON CHARLES K & CHERYL N TRSTES CHARLES K ANDERSON RT 2311 MAIN STREET BREWSTER, MA 02631				78-2-0				2311 MAIN STREET			
TRANSFER HISTORY				DOS	T	SALE PRICE	BK-PG (Cert)				
ANDERSON CHARLES K & CHER				03/15/2005	F		19616-109				
ANDERSON C K				03/07/2001	A		13618-250				
ANDERSON C K & CHERYL N				01/29/2001	QS	500,000	13519-113				

CLASS	CLASS%	DESCRIPTION			BN ID	BN	CARD	
1010	100	SINGLE FAMILY				1	1 of 1	
PMT NO	PMT DT	TY	DESC	AMOUNT	INSP	BY	1st	%
845	10/16/2014	7	ALTERATIONS	3,300	05/27/2015	MW	100	100
551	07/02/2013	7	ALTERATIONS	7,200	08/09/2014	RJM	100	100
311	04/11/2013	7	ALTERATIONS	20,000	08/09/2014	RJM	100	100
283	07/17/1992	5	OTHER	2,800	01/01/1995	RD	100	100
76	03/17/1992	4	COMM BLDG	18,000	01/01/1995	RD	100	100

LAND

CD	T	AC/SF/UN	Nbhd	St Ind	Infl	ADJ BASE	SAF	Topo	Lpi	VC	CREDIT AMT	ADJ VALUE
100	S	29,900	10	1.00	A	1.00	A	1.00				243,660

TOTAL	29,900 SF	ZONING	RM	FRNT	0	ASSESSED	CURRENT	PREVIOUS
Nbhd	NBHD 10	NOTE				LAND	243,700	229,900
St Ind	AVERAGE		BUILDING	556,200	525,400			
Infl	AVERAGE		DETACHED	33,500	33,100			
			OTHER	0	0			
TOTAL						833,400	788,400	

DETAILED

TY	QUAL	COND	DIM/NOTE	YB	UNITS	ADJ PRICE	RCNLD	PHOTO	05/27/2015
GHG	A	1.00	50 0.50		800	23.50	9,400		
UTB	A	1.00	01 1.00		864	27.90	24,100		

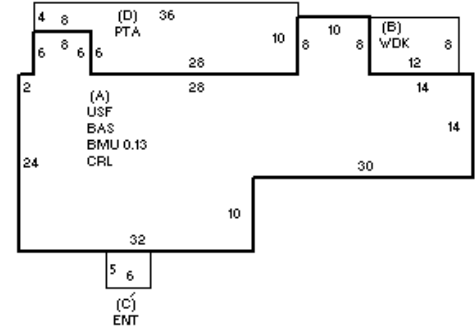

BUILDING

BUILDING	CD	ADJ	DESC	MEASURE	12/11/2007	JH	BLDG COMMENTS
MODEL	1		RESIDENTIAL	LIST	1/5/2008	REO	FORMERLY POOR HOUSE-- NOWGREENHOUSE
STYLE	7	1.05	CONVEN/OLD [100%]	REVIEW	1/7/2008	SEJ	
QUALITY	G	1.30	GOOD [100%]				
FRAME	1	1.00	WD FRAME [100%]				

YEAR BLT	1800	SIZE ADJ	0.990	ELEMENT	CD	DESCRIPTION	ADJ	S	BAT	T	DESCRIPTION	UNITS	YB	ADJ PRICE	RCN	TOTAL RCN	869,013		
NET AREA	2,632	DETAIL ADJ	1.000	FOUNDATION	4	FLR & WALL	1.00	A	CRL	N	BSMT CRAWL	1,316		33.36	43,896	CONDITION ELEM	CD		
\$NLA(RCN)	\$330	OVERALL	1.050	EXT COVER	1	WD SHINGLE	1.00	A	BMU	N	BSMT UNFINISHED	171		90.34	15,447	EXTERIOR	G		
				ROOF SHAPE	1	GABLE	1.00	A	BAS	L	BASE AREA	1,316	1800	333.11	438,370	INTERIOR	A		
				ROOF COVER	1	ASPH/CMP SH	1.00	A	USF	L	UPPER STORY FIN	1,316	1800	228.16	300,261	KITCHEN	A		
				FLOOR COVER	2	SOFTWOOD	1.00	B	WDK	N	WOOD DECK	96		52.97	5,085	BATHS	G		
				INT FINISH	1	PLASTER	1.00	C	ENT	N	ENCLOSED ENTRY	30		175.18	5,255	HEAT/ELEC	A		
				HEATING/COOL	2	HOT WATER	1.00	D	PTA	N	PATIO	312		18.26	5,699				
				FUEL SOURCE	2	GAS	1.00	F22	O		FPL 2S 2OP	2		16,853.35	33,707				
																		EFF.YR/AGE	1961 / 62
																		COND	36 36 %
																		FUNC	0
																		ECON	0
																		DEPR	36 % GD 64
																		RCNLD	\$556,200