

Key: 2070

Town of BREWSTER - Fiscal Year 2025

9/17/2024 2:15 pm SEQ #: 2.222

LEGAL

CURRENT OWNER		PARCEL ID		LOCATION	
HARB RICHARD J & JOYCE L		49-32-0		96 AMBERGRIS CIRCLE	
96 AMBERGRIS CIRCLE		TRANSFER HISTORY		DOS	T
BREWSTER, MA 02631		HARB RICHARD J & JOYCE L		11/08/1990	A
		SALE PRICE	BK-PG (Cert)		
		100	7348-264		

CLASS	CLASS%	DESCRIPTION			BN ID	BN	CARD	
1010	100	SINGLE FAMILY				1	1 of 1	
PMT NO	PMT DT	TY	DESC	AMOUNT	INSP	BY	1st	%
23-633	05/29/2023	7	ALTERATIONS	22,500	04/15/2024	NF	100	100
42	02/09/2004	2	ADD	4,000	05/10/2005	JB	100	100
687	11/07/2003	2	ADD	75,000	05/10/2005	JB	100	100

LAND

CD	T	AC/SF/UN	Nbhd	St Ind	Infl	ADJ BASE	SAF	Topo	Lpi	VC	CREDIT AMT	ADJ VALUE				
100	S	22,690	2	1.00	2-A	1.00	A	1.00	767,200	2.00	A	1.00	R19	3.50		799,690

TOTAL	22,690 SF	ZONING	RM	FRNT	0	ASSESSED	CURRENT	PREVIOUS
Nbhd	NBHD 2	N O T E	WATERVIEW			LAND	799,700	754,500
St Ind	SALTWORKS		LAND	817,500	771,800			
Infl	AVERAGE		DETACHED	0	0			
			OTHER	0	0			
			TOTAL	1,617,200	1,526,300			

DETACHED

TY	QUAL	COND	DIM/NOTE	YB	UNITS	ADJ PRICE	RCNLD

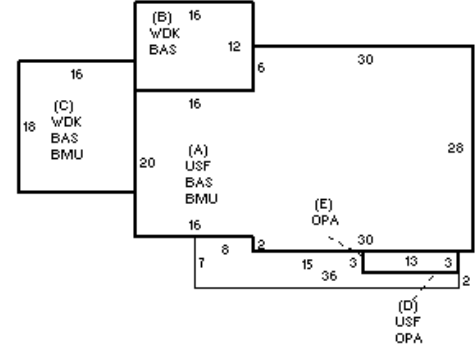

BUILDING

BUILDING	CD	ADJ	DESC	MEASURE	2/22/2018	NF
MODEL	1		RESIDENTIAL	LIST	2/22/2018	EST
STYLE	5	1.05	COLONIAL [100%]	REVIEW	5/16/2024	EMZ
QUALITY	G	1.30	GOOD [100%]	BLDG COMMENTS		
FRAME	1	1.00	WD FRAME [100%]	GENERATOR		

YEAR BLT	1984	SIZE ADJ	0.990
NET AREA	2,839	DETAIL ADJ	1.000
\$NLA(RCN)	\$365	OVERALL	1.100
CAPACITY		UNITS	ADJ
STORIES	2	1.00	
ROOMS	8	1.00	
BEDROOMS	5	1.00	
BATHROOMS	2	1.00	
FIXTURES	6	\$11,154	
GARAGE SPACES	2	1.00	
% BSMT FIN	0	1.00	
# 1/2 BATHS	0	1.00	
# OF UNITS	1	1.00	

ELEMENT	CD	DESCRIPTION	ADJ
FOUNDATION	4	FLR & WALL	1.00
EXT COVER	1	WD SHINGLE	1.00
ROOF SHAPE	1	GABLE	1.00
ROOF COVER	1	ASPH/CMP SH	1.00
FLOOR COVER	3	W/W CARPET	1.00
INT FINISH	1	PLASTER	1.00
HEATING/COOL	11	HTWT/CL AIR	1.05
FUEL SOURCE	2	GAS	1.00

S	BAT	T	DESCRIPTION	UNITS	YB	ADJ PRICE	RCN
+	BMU	N	BSMT UNFINISHED	1,448		74.51	107,883
A	BAS	L	BASE AREA	1,160	1984	335.01	388,613
A	USF	L	UPPER STORY FIN	1,160	1984	249.65	289,594
B	BAS	L	BASE AREA	192	2001	335.01	64,322
+	WDK	N	WOOD DECK	480		55.50	26,638
C	BAS	L	BASE AREA	288	2003	335.01	96,483
+	OPA	N	OPEN PORCH	196		70.79	13,874
D	USF	L	UPPER STORY FIN	39	2004	249.64	9,736
	BMG	O	BSMT GARAGE	2		4,379.45	8,759
	F21	O	FPL 2S 1OP	1		14,370.80	14,371
	ODS	O	OUTDOOR SHOWER	1		3,418.90	3,419

TOTAL RCN	1,034,845	
CONDITION ELEM		CD
EXTERIOR		G
INTERIOR		A
KITCHEN		A
BATHS		A
HEAT/ELEC		A
EFF.YR/AGE	1991 / 32	
COND	21	21 %
FUNC	0	
ECON	0	
DEPR	21	% GD 79
RCNLD	\$817,500	