

Key: 2084

Town of BREWSTER - Fiscal Year 2025

9/17/2024 2:15 pm SEQ #: 2.236

LEGAL LAND

Table with columns: CURRENT OWNER, PARCEL ID, LOCATION, TRANSFER HISTORY, DOS, T, SALE PRICE, BK-PG (Cert), CD, T, AC/SF/UN, Nbh, St Ind, Infl, ADJ BASE, SAF, Topo, Lpi, VC, CREDIT AMT, ADJ VALUE.

Table with columns: CLASS, CLASS%, DESCRIPTION, BN ID, BN, CARD, PMT NO, PMT DT, TY, DESC, AMOUNT, INSP, BY, 1st, %.

Table with columns: TOTAL, 19,900 SF, ZONING, RM, FRNT, 0, ASSESSED, CURRENT, PREVIOUS, Nbhd, St Ind, Infl, LAND, BUILDING, DETACHED, OTHER, TOTAL.

Table with columns: TY, QUAL, COND, DIM/NOTE, YB, UNITS, ADJ PRICE, RCNLD, SHF, A, 1.00, 01, 1.00, 10X12, 2019, 120, 21.39, 2,600.

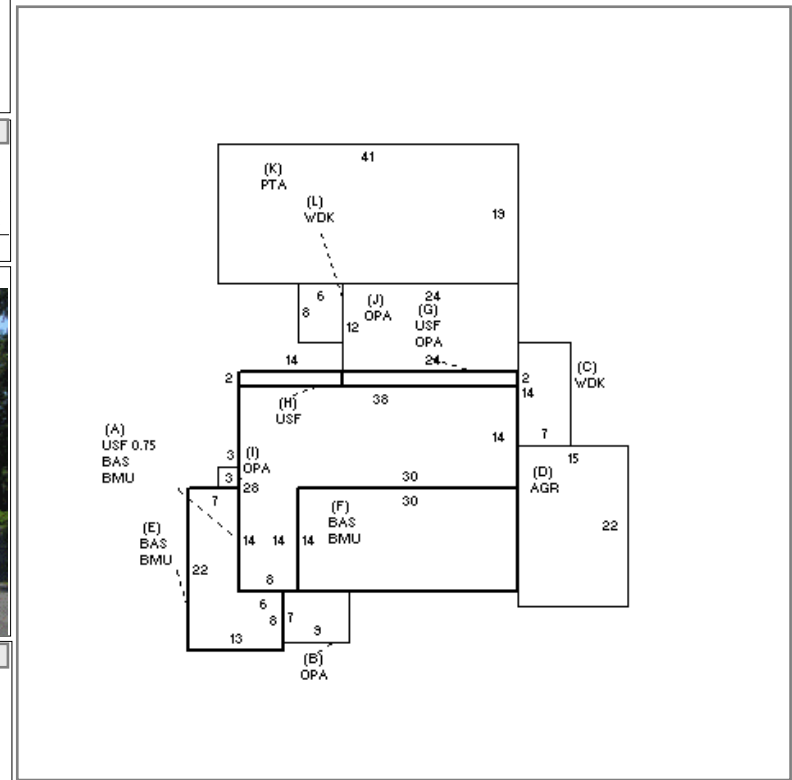

Table with columns: BUILDING, CD, ADJ, DESC, MEASURE, 2/28/2018, NF, MODEL, STYLE, QUALITY, FRAME, LIST, REVIEW.

Table with columns: YEAR BLT, SIZE ADJ, NET AREA, \$NLA(RCN), CAPACITY, UNITS, ADJ, STORIES, ROOMS, BEDROOMS, BATHROOMS, FIXTURES, GARAGE SPACES, % BSMT FIN, # 1/2 BATHS, # OF UNITS.

Table with columns: ELEMENT, CD, DESCRIPTION, ADJ, S, BAT, T, DESCRIPTION, UNITS, YB, ADJ PRICE, RCN, FOUNDATION, EXT COVER, ROOF SHAPE, ROOF COVER, FLOOR COVER, INT FINISH, HEATING/COOL, FUEL SOURCE.

Table with columns: TOTAL RCN, CONDITION ELEM, CD, EXTERIOR, INTERIOR, KITCHEN, BATHS, HEAT/ELEC, EFF. YR/AGE, COND, FUNC, ECON, DEPR, RCNLD.

DETACHED

BUILDING

LAND