

Key: 2123

Town of BREWSTER - Fiscal Year 2025

9/17/2024 2:15 pm SEQ #: 2.275

LEGAL

LAND

DETACHED

BUILDING

| CURRENT OWNER  |  |  |  |            |    | PARCEL ID                 |          |  |  | LOCATION          |    |            |              |
|--|--|--|--|------------|----|---------------------------|----------|--|--|-------------------|----|------------|--------------|
| KUJALA JONATHAN P & JULIE A TRUSTEES<br>KUJALA FAMILY TRUST OF 2015<br>24 PAUGUS TRAIL<br>GROTON, MA 01450 |  |  |  |            |    | 49-23-0                   |          |  |  | 18 BLUE FISH LANE |    |            |              |
|  |  |  |  |            |    | TRANSFER HISTORY          |          |  |  | DOS               | T  | SALE PRICE | BK-PG (Cert) |
|  |  |  |  |            |    | KUJALA JONATHAN P & JULIE |          |  |  | 08/15/2022        | QS | 2,200,000  | 35308-77     |
| KUHN KEEGAN & RACHAEL  |  |  |  | 09/20/2018 | QS | 993,500                   | 31540-88 |  |  |                   |    |            |              |
| BELANGER DANIEL JR & KATHL   |  |  |  | 07/01/2009 | QS | 850,000                   | 23859-77 |  |  |                   |    |            |              |

| CLASS  | CLASS%     | DESCRIPTION   |              |           | BN ID      | BN  | CARD   |     |
|--------|------------|---------------|--------------|-----------|------------|-----|--------|-----|
| 1010   | 100        | SINGLE FAMILY |              |           |            | 1   | 1 of 1 |     |
| PMT NO | PMT DT     | TY            | DESC         | AMOUNT    | INSP       | BY  | 1st    | %   |
| 1045   | 08/15/2022 | 15            | SALE REVIEW  | 2,200,000 | 06/14/2023 | JMG | 100    | 100 |
| 1004   | 12/07/2018 | 10            | INGROUND POO | 120,000   | 07/07/2020 | NF  | 100    | 100 |
| 634    | 11/28/2018 | 7             | ALTERATIONS  | 69,150    | 06/17/2019 | NF  | 100    | 100 |
| 517    | 09/19/2006 | 2             | ADD          | 130,000   | 07/10/2007 | JH  | 100    | 100 |
|        | 08/02/2006 | 6             | DEMO         | 7,500     | 07/10/2007 | JH  | 100    | 100 |

| CD  | T | AC/SF/UN | Nbhd | St Ind | Infl | ADJ BASE | SAF | Topo | Lpi | VC | CREDIT AMT | ADJ VALUE |
|-----|---|----------|------|--------|------|----------|-----|------|-----|----|------------|-----------|
| 100 | S | 15,580   | 2    | 1.00   | 2-A  | 1.00     | A   | 1.00 |     |    |            | 747,450   |

| TOTAL  | 15,580 SF | ZONING | RM           | FRNT             | 0                | ASSESSED | CURRENT | PREVIOUS |
|--------|-----------|--------|--------------|------------------|------------------|----------|---------|----------|
| Nbhd   | NBHD 2    | NOTE   | LAND         | 747,500          | 705,200          |          |         |          |
| St Ind | SALTWORKS |        | BUILDING     | 947,900          | 904,400          |          |         |          |
| Infl   | AVERAGE   |        | DETACHED     | 37,300           | 36,800           |          |         |          |
|        |           |        | OTHER        | 0                | 0                |          |         |          |
|        |           |        | <b>TOTAL</b> | <b>1,732,700</b> | <b>1,646,400</b> |          |         |          |

| TY  | QUAL | COND | DIM/NOTE | YB         | UNITS | ADJ PRICE | RCNLD  |
|-----|------|------|----------|------------|-------|-----------|--------|
| PLH | G    | 1.20 | 20 0.80  | 10X14      | 140   | 55.97     | 6,300  |
| IPV | G    | 1.20 | 01 1.00  | EST 16X28  | 2018  | 47.31     | 21,200 |
| HTB | G    | 1.20 | 01 1.00  |            | 2018  | 4,869.72  | 4,900  |
| PTD | G    | 1.20 | 01 1.00  | POOL PATIO | 2018  | 8.10      | 4,900  |



| BUILDING | CD | ADJ  | DESC            | MEASURE | 2/27/2018 | NF  |
|----------|----|------|-----------------|---------|-----------|-----|
| MODEL    | 1  |      | RESIDENTIAL     | LIST    | 7/10/2007 | JH  |
| STYLE    | 4  | 1.02 | CAPE [100%]     | REVIEW  | 6/14/2023 | JMG |
| QUALITY  | G+ | 1.45 | GOOD + [100%]   |         |           |     |
| FRAME    | 1  | 1.00 | WD FRAME [100%] |         |           |     |

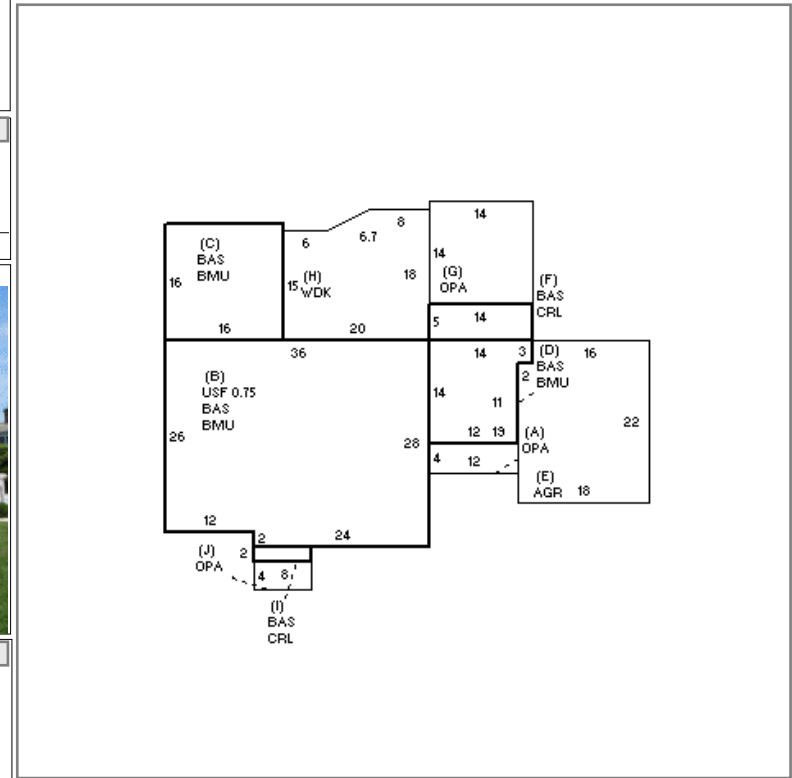

| YEAR BLT      | 1978  | SIZE ADJ   | 1.000    |
|---------------|-------|------------|----------|
| NET AREA      | 2,238 | DETAIL ADJ | 1.000    |
| \$NLA(RCN)    | \$432 | OVERALL    | 1.050    |
| CAPACITY      |       | UNITS      | ADJ      |
| STORIES       |       | 1.75       | 1.00     |
| ROOMS         |       | 7          | 1.00     |
| BEDROOMS      |       | 4          | 1.00     |
| BATHROOMS     |       | 3          | 1.00     |
| FIXTURES      |       | 9          | \$17,813 |
| GARAGE SPACES |       | 1          | 1.00     |
| % BSMT FIN    |       | 0          | 1.00     |
| # 1/2 BATHS   |       | 0          | 1.00     |
| # OF UNITS    |       | 1          | 1.00     |

| ELEMENT      | CD | DESCRIPTION | ADJ  | S | BAT | T | DESCRIPTION     | UNITS | YB   | ADJ PRICE | RCN     |
|--------------|----|-------------|------|---|-----|---|-----------------|-------|------|-----------|---------|
| FOUNDATION   | 4  | FLR & WALL  | 1.00 | + | OPA | N | OPEN PORCH      | 276   |      | 76.13     | 21,011  |
| EXT COVER    | 1  | WD SHINGLE  | 1.00 | + | BMU | N | BSMT UNFINISHED | 1,414 |      | 80.13     | 113,298 |
| ROOF SHAPE   | 1  | GABLE       | 1.00 | B | BAS | L | BASE AREA       | 984   | 1978 | 367.79    | 361,906 |
| ROOF COVER   | 1  | ASPH/CMP SH | 1.00 | B | USF | L | UPPER STORY FIN | 738   | 2006 | 279.91    | 206,573 |
| FLOOR COVER  | 1  | HARDWOOD    | 1.00 | + | BAS | L | BASE AREA       | 516   | 2006 | 367.79    | 189,780 |
| INT FINISH   | 2  | DRYWALL     | 1.00 | E | AGR | N | ATT GARAGE      | 390   |      | 63.00     | 24,569  |
| HEATING/COOL | 9  | WARM/CL AIR | 1.03 | F | CRK | N | BSMT CRAWL      | 70    |      | 46.24     | 3,237   |
| FUEL SOURCE  | 2  | GAS         | 1.00 | H | WDK | N | WOOD DECK       | 333   |      | 59.68     | 19,875  |
|              |    |             |      | I | CRK | N | BSMT CRAWL      | 16    |      | 46.24     | 740     |
|              |    |             |      |   | GFP | O | GAS FIREPLACE   | 1     |      | 4,759.30  | 4,759   |
|              |    |             |      |   | ODS | O | OUTDOOR SHOWER  | 1     |      | 3,676.80  | 3,677   |

| TOTAL RCN      | 967,237   |
|----------------|-----------|
| CONDITION ELEM | CD        |
| EXTERIOR       | G         |
| INTERIOR       | V         |
| KITCHEN        | E         |
| BATHS          | V         |
| HEAT/ELEC      | G         |
| EFF.YR/AGE     | 2021 / 2  |
| COND           | 2 2 %     |
| FUNC           | 0         |
| ECON           | 0         |
| DEPR           | 2 % GD 98 |
| RCNLD          | \$947,900 |