

Key: 2286

Town of BREWSTER - Fiscal Year 2025

9/17/2024 2:15 pm SEQ #: 2.441

LEGAL

CURRENT OWNER		PARCEL ID		LOCATION	
BURGESS FRANCIS J C/O CONNOLLY MICHAEL F & MONICA B 397 MAIN STREET BREWSTER, MA 02631		16-8-0		397 MAIN STREET	
TRANSFER HISTORY		DOS	T	SALE PRICE	BK-PG (Cert)
CONNOLLY MICHAEL F & MONI		08/26/2024	QS	1,500,000	36533-44
BURGESS FRANCIS J		09/23/2021	F	1	34499-266
BURGESS DONNA M		04/22/2002	QS	284,500	15071-208

CLASS	CLASS%	DESCRIPTION			BN ID	BN	CARD	
1010	100	SINGLE FAMILY				1	1 of 1	
PMT NO	PMT DT	TY	DESC	AMOUNT	INSP	BY	1st	%
498	09/01/2005	2	ADD	20,000	06/21/2006	JB	100	100
115	03/19/2004	1	NEW CONSTRUC	325,000	06/06/2005	JB	100	100

LAND

CD	T	AC/SF/UN	Nbhd	St Ind	Infl	ADJ BASE	SAF	Topo	Lpi	VC	CREDIT AMT	ADJ VALUE				
100	S	60,000	10	1.00	A	1.00	A	1.00	219,200	1.00	A	1.00	R03	1.00		303,350
300	A	0.604	10	1.00	A	1.00	A	1.00	12,000	1.00	A	1.00	R03	1.00		7,250
350	A	0.147	10	1.00	A	1.00	A	1.00	2,100	1.00	A	1.00	TWP	1.00		310

TOTAL	2.128 Acres	ZONING	RM	FRNT	0	ASSESSED	CURRENT	PREVIOUS
Nbhd	NBHD 10	N O T E	SURVEY FOR F/Y 2004 PLAN BOOK 573/14			LAND	310,900	293,300
St Ind	AVERAGE		BUILDING	778,100	743,900			
Infl	AVERAGE		DETACHED	0	0			
			OTHER	0	0			
						TOTAL	1,089,000	1,037,200

DETACHED

TY	QUAL	COND	DIM/NOTE	YB	UNITS	ADJ PRICE	RCNLD

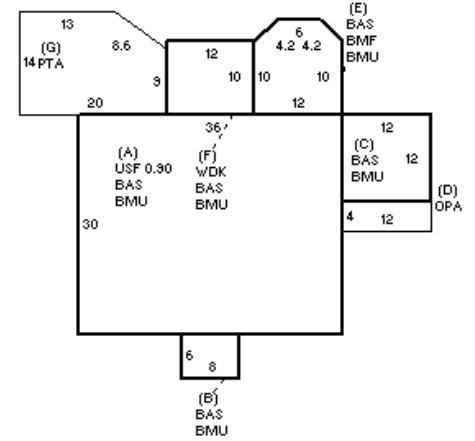

BUILDING

BUILDING	CD	ADJ	DESC	MEASURE	1/11/2018	NF
MODEL	1		RESIDENTIAL	LIST	1/11/2018	NF
STYLE	4	1.02	CAPE [100%]	REVIEW	12/16/2019	MR
QUALITY	G	1.30	GOOD [100%]			
FRAME	1	1.00	WD FRAME [100%]			

BLDG COMMENTS
PULL DOWN TO ATTIC BMF=OFFICE

G

YEAR BLT	2004	SIZE ADJ	0.990	ELEMENT	CD	DESCRIPTION	ADJ	S	BAT	T	DESCRIPTION	UNITS	YB	ADJ PRICE	RCN	TOTAL RCN	915,396
NET AREA	2,511	DETAIL ADJ	1.000	FOUNDATION	4	FLR & WALL	1.00	+	BMU	N	BSMT UNFINISHED	1,539		71.12	109,451		
\$NLA(RCN)	\$365	OVERALL	1.050	EXT COVER	1	WD SHINGLE	1.00	+	BAS	L	BASE AREA	1,539	2004	326.45	502,400		
				ROOF SHAPE	1	GABLE	1.00	A	USF	L	UPPER STORY FIN	972	2004	245.91	239,023		
				ROOF COVER	1	ASPH/CMP SH	1.00	D	OPA	N	OPEN PORCH	48		67.57	3,243		
				FLOOR COVER	1	HARDWOOD	1.00	E	BMF	N	BSMT FINISH	147		54.50	8,012		
				INT FINISH	2	DRYWALL	1.00	F	WDK	N	WOOD DECK	120		52.97	6,357		
				HEATING/COOL	9	WARM/CL AIR	1.03	G	PTA	N	PATIO	263		19.34	5,087		
				FUEL SOURCE	1	OIL	1.00		F21	O	FPL 2S 1OP	1		13,717.60	13,718		
									ODS	O	OUTDOOR SHOWER	1		3,263.50	3,264		
																CONDITION ELEM	CD
																EXTERIOR	A
																INTERIOR	A
																KITCHEN	A
																BATHS	A
																HEAT/ELEC	A
																EFF.YR/AGE	2004 / 19
																COND	15 15 %
																FUNC	0
																ECON	0
																DEPR	15 % GD 85
																RCNLD	\$778,100