

Key: 2314

Town of BREWSTER - Fiscal Year 2025

9/17/2024 2:15 pm SEQ #: 2.471

LEGAL

LAND

DETACHED

BUILDING

CURRENT OWNER		PARCEL ID		LOCATION												
WIHARA LLC 1974 BEECHWOOD BOULEVARD PITTSBURGH, PA 15217		6-25-0		95 STONY BROOK ROAD												
TRANSFER HISTORY		DOS	T	SALE PRICE	BK-PG (Cert)											
WIHARA LLC		07/27/2021	B	1 (227042)												
KALSON DAVID J & SUSAN FR		01/12/2021	P	275,000 (225058)												
HARRIGAN KEVIN D		11/16/2018	V	525,000 (217911)												
CD	T	AC/SF/UN	Nbhd	St Ind	Infl	ADJ BASE	SAF	Topo	Lpi	VC	CREDIT AMT	ADJ VALUE				
100	S	60,000	12	1.00	12M	1.00	A	1.00	252,080	1.00	A	1.00	RM5	1.15		348,850
300	A	0.278	12	1.00	12M	1.00	A	1.00	13,800	1.00	A	1.00	RM5	1.15		3,840

TOTAL	1.655 Acres	ZONING	RM	FRNT	0	ASSESSED	CURRENT	PREVIOUS
Nbhd	NBHD 12	N O T E	#95 per FD 2/4/21			LAND	352,700	332,700
St Ind	STONYBROOK		LAND	1,258,800	1,201,600			
Infl	AVERAGE		BUILDING	39,000	38,700			
			DETACHED	0	0			
					OTHER			
					TOTAL	1,650,500	1,573,000	

TY	QUAL	COND	DIM/NOTE	YB	UNITS	ADJ PRICE	RCNLD	
IPG	A	1.00	01 1.00	18X50	2022	900	43.36	39,000



BLDG COMMENTS
BMF=FAM RM/GYM/BATH
INTERIOR ESTIMATED PER PLANS

CLASS	CLASS%	DESCRIPTION		BN ID	BN	CARD	
1010	100	SINGLE FAMILY			1	1 of 1	
PMT NO	PMT DT	TY	DESC	AMOUNT	INSP	BY	1st %
491	06/06/2022	10	INGROUND POO	100,000	03/24/2023	TCK	100 100
661	07/21/2021	7	ALTERATIONS	1,200	05/10/2022	TCK	100 100
375	04/21/2021	1	NEW CONSTRUC	1,100,000	03/24/2023	TCK	100 100
	01/12/2021	15	SALE REVIEW	275,000	02/08/2022	JMG	100 100
	01/03/2018	5	OTHER		01/03/2018	JMG	100 100

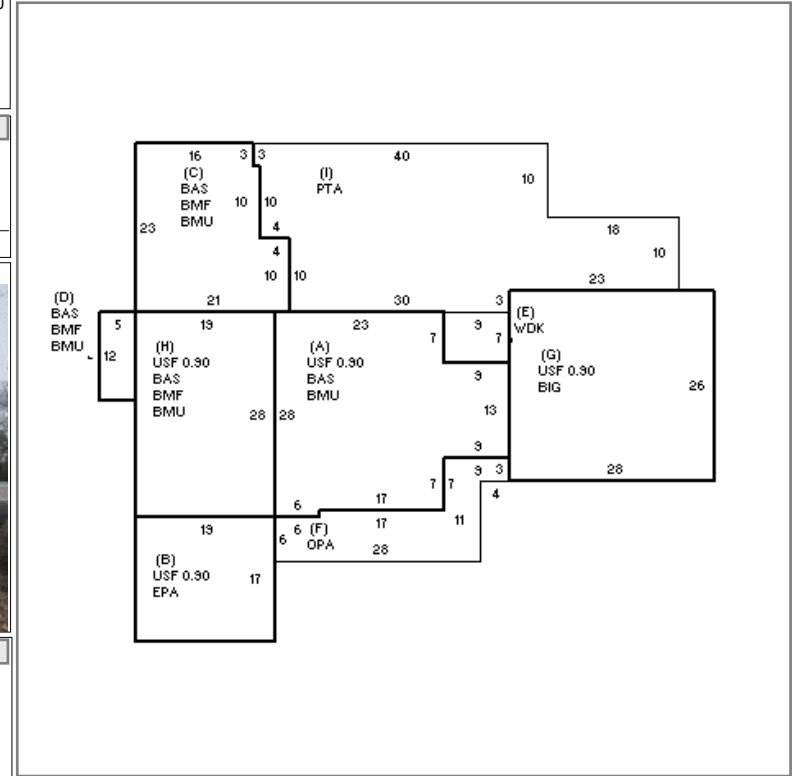

BUILDING	CD	ADJ	DESC	MEASURE	5/10/2022	TCK
MODEL	1		RESIDENTIAL	LIST	5/10/2022	EST
STYLE	4	1.02	CAPE [100%]	REVIEW	4/10/2023	EMZ
QUALITY	G	1.30	GOOD [100%]			
FRAME	1	1.00	WD FRAME [100%]			

YEAR BLT	2021	SIZE ADJ	0.970
NET AREA	3,858	DETAIL ADJ	1.000
\$NLA(RCN)	\$333	OVERALL	1.050
CAPACITY		UNITS	ADJ
STORIES		1.9	1.00
ROOMS		8	1.00
BEDROOMS		5	1.00
BATHROOMS		5	1.00
FIXTURES		19	\$33,716
GARAGE SPACES		2	1.00
% BSMT FIN		57	1.00
# 1/2 BATHS		1	1.00
# OF UNITS		1	1.00

ELEMENT	CD	DESCRIPTION	ADJ	S	BAT	T	DESCRIPTION	UNITS	YB	ADJ PRICE	RCN
FOUNDATION	4	FLR & WALL	1.00	+	BMU	N	BSMT UNFINISHED	1,764		67.73	119,474
EXT COVER	1	WD SHINGLE	1.00	+	BAS	L	BASE AREA	1,764	2021	313.32	552,702
ROOF SHAPE	1	GABLE	1.00	+	USF	L	UPPER STORY FIN	2,094	2021	193.75	405,704
ROOF COVER	1	ASPH/CMP SH	1.00	B	EPA	N	ENCLOSED PORCH	323		90.60	29,263
FLOOR COVER	1	HARDWOOD	1.00	+	BMF	N	BSMT FINISH	1,020		45.11	46,012
INT FINISH	2	DRYWALL	1.00	E	WDK	N	WOOD DECK	63		51.91	3,270
HEATING/COOL	9	WARM/CL AIR	1.03	F	OPA	N	OPEN PORCH	237		66.20	15,690
FUEL SOURCE	2	GAS	1.00	G	BIG	N	BUILT-IN GARAGE	728		62.97	45,841
				I	PTA	N	PATIO	1,025		15.79	16,184
					F21	O	FPL 2S 1OP	1		13,440.40	13,440
					GEN	O	GENERATOR	1		0.00	
					ODS	O	OUTDOOR SHOWER	1		3,197.60	3,198

TOTAL RCN	1,284,494
CONDITION ELEM	CD
EXTERIOR	A
INTERIOR	A
KITCHEN	A
BATHS	A
HEAT/ELEC	A
EFF.YR/AGE	2021 / 2
COND	2 2 %
FUNC	0
ECON	0
DEPR	2 % GD 98
RCNLD	\$1,258,800