

Key: 2512

Town of BREWSTER - Fiscal Year 2025

9/17/2024 2:15 pm SEQ #: 2.670

LEGAL

LAND

DETACHED

BUILDING

CURRENT OWNER				PARCEL ID				LOCATION			
TOBIN NINA TRUSTEE TOBIN FAMILY REVOCABLE TRUST 577 MAIN STREET BREWSTER, MA 02631				26-14-0				577 MAIN STREET			
TRANSFER HISTORY				DOS	T	SALE PRICE		BK-PG (Cert)			
TOBIN NINA TRUSTEE				10/26/2012	QS	410,000		(198551)			
O'BRIEN DENNIS R & DOROTH				01/28/2000	QS	85,000		(156445)			
LAHIVE MARILYN L				06/14/1978	XX			(74471)			

CLASS	CLASS%	DESCRIPTION			BN ID	BN	CARD	
1010	100	SINGLE FAMILY				1	1 of 1	
PMT NO	PMT DT	TY	DESC	AMOUNT	INSP	BY	1st	%
707	04/14/2023	22	I & E					0
220	02/25/2022	22	I & E					0
271	08/27/2013	7	ALTERATIONS	7,440	06/02/2014	RJM	100	100
	04/26/2001	5	OTHER	8,500	05/07/2002	SJM	100	100
	05/05/2000	1	NEW CONSTRUC	130,000	05/03/2001	LB	100	100

CD	T	AC/SF/UN	Nbhd	St Ind	Infl	ADJ BASE	SAF	Topo	Lpi	VC	CREDIT AMT	ADJ VALUE
100	S	30,000	10	1.00	A	1.00	A	1.00		R03	1.00	243,880

TOTAL	30,056 SF	ZONING	RM	FRNT	0	ASSESSED	CURRENT	PREVIOUS
Nbhd	NBHD 10	N O T E S S A N D R I G H T S E X P U N G B Y C O U R T O R D E R D O C # 6 3 7 8 5 8 4 /2 1 /9 5	LAND	243,900	230,100			
St Ind	AVERAGE		BUILDING	532,400	508,800			
Infl	AVERAGE		DETACHED	2,500	2,500			
			OTHER	0	0			
TOTAL				778,800	741,400			

TY	QUAL	COND	DIM/NOTE	YB	UNITS	ADJ PRICE	RCNLD
SHF	G	1.20	01 1.00	8X12	96	26.41	2,500



BLDG COMMENTS		
FLOOR=LAMINATE	Area over garage has 4 ft	
	kneewalls for a full USF.	

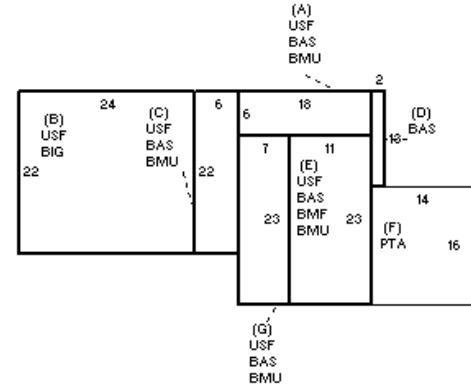

BUILDING	CD	ADJ	DESC	MEASURE	12/17/2007	JH
MODEL	1		RESIDENTIAL	LIST	12/17/2007	JH
STYLE	5	1.05	COLONIAL [100%]	REVIEW	7/28/2014	RJM
QUALITY	G-	1.20	GOOD - [100%]			
FRAME	1	1.00	WD FRAME [100%]			

YEAR BLT	2000	SIZE ADJ	1.000	ELEMENT	CD	DESCRIPTION	ADJ	S	BAT	T	DESCRIPTION	UNITS	YB	ADJ PRICE	RCN	TOTAL RCN	626,304			
NET AREA	1,862	DETAIL ADJ	1.000	FOUNDATION	4	FLR & WALL	1.00	+	BMU	N	BSMT UNFINISHED	654		78.50	51,341	CONDITION ELEM	CD			
\$NLA(RCN)	\$336	OVERALL	1.050	EXT COVER	2	CLAPBOARD	1.00	+	USF	L	UPPER STORY FIN	1,182	2000	222.19	262,633	EXTERIOR	G			
				ROOF SHAPE	1	GABLE	1.00	B	BIG	N	BUILT-IN GARAGE	528		62.71	33,112	INTERIOR	A			
				ROOF COVER	1	ASPH/CMP SH	1.00	+	BAS	L	BASE AREA	680	2000	366.50	249,218	KITCHEN	A			
				FLOOR COVER	6	OTHER	1.00	E	BMF	N	BSMT FINISH	253		50.82	12,858	BATHS	A			
				INT FINISH	2	DRYWALL	1.00	F	PTA	N	PATIO	224		18.03	4,038	HEAT/ELEC	A			
				HEATING/COOL	2	HOT WATER	1.00													
				FUEL SOURCE	1	OIL	1.00													
																		EFF.YR/AGE	2003 / 20	
																		COND	15 15 %	
																		FUNC	0	
																		ECON	0	
																		DEPR	15 % GD 85	
																		RCNLD	\$532,400	