

Key: 2563

Town of BREWSTER - Fiscal Year 2025

9/17/2024 2:15 pm SEQ #: 2.725

LEGALS

| CURRENT OWNER   |  | PARCEL ID  |    | LOCATION              |              |
|---|--|------------|----|-----------------------|--------------|
| BERRICK STEPHEN L &<br>FOX CYNTHIA J<br>135 PAINES CREEK ROAD<br>BREWSTER, MA 02631 |  | 36-12-0    |    | 135 PAINES CREEK ROAD |              |
| TRANSFER HISTORY  |  | DOS        | T  | SALE PRICE            | BK-PG (Cert) |
| BERRICK STEPHEN L &   |  | 01/16/1981 | XX | 12,500                | 3225-198     |

| CLASS  | CLASS%     | DESCRIPTION   |              | BN ID   | BN         | CARD   |         |
|--------|------------|---------------|--------------|---------|------------|--------|---------|
| 1010   | 100        | SINGLE FAMILY |              |         | 1          | 1 of 1 |         |
| PMT NO | PMT DT     | TY            | DESC         | AMOUNT  | INSP       | BY     | 1st %   |
| 860    | 10/30/2017 | 2             | ADD          | 126,000 | 07/30/2019 | NF     | 100 100 |
| 394    | 04/25/2013 | 5             | OTHER        | 9,965   | 08/09/2014 | RJM    | 100 100 |
| 53     | 02/25/2009 | 7             | ALTERATIONS  | 5,000   | 04/07/2010 | JH     | 100 100 |
| 289    | 05/28/1999 | 2             | ADD          | 25,000  | 02/09/2000 | LB     | 100 100 |
| 573    | 10/08/1997 | 3             | OUT BUILDING | 1,800   | 02/09/2000 | LB     | 100 100 |

LAND

| CD  | T | AC/SF/UN | Nbhd    | St Ind | Infl   | ADJ BASE | SAF  | Topo   | Lpi      | VC | CREDIT AMT | ADJ VALUE |
|-----|---|----------|---------|--------|--------|----------|------|--------|----------|----|------------|-----------|
| 100 | S | 29,271   | 12 1.00 | A 1.00 | A 1.00 | 219,200  | 1.64 | A 1.00 | RM3 1.00 |    |            | 242,210   |

|        |           |        |          |         |         |          |         |          |
|--------|-----------|--------|----------|---------|---------|----------|---------|----------|
| TOTAL  | 29,271 SF | ZONING | RM       | FRNT    | 0       | ASSESSED | CURRENT | PREVIOUS |
| Nbhd   | NBHD 12   | NOTE   |          |         |         | LAND     | 242,200 | 228,500  |
| St Ind | AVERAGE   |        | BUILDING | 589,000 | 563,300 |          |         |          |
| Infl   | AVERAGE   |        | DETACHED | 2,600   | 2,500   |          |         |          |
|        |           |        | OTHER    | 0       | 0       |          |         |          |
|        |           |        |          |         |         | TOTAL    | 833,800 | 794,300  |

DETACHED

| TY  | QUAL | COND         | DIM/NOTE | YB   | UNITS | ADJ PRICE | RCNLD |
|-----|------|--------------|----------|------|-------|-----------|-------|
| SHF | A    | 1.00 01 1.00 | 12 X 10  | 1999 | 120   | 21.39     | 2,600 |

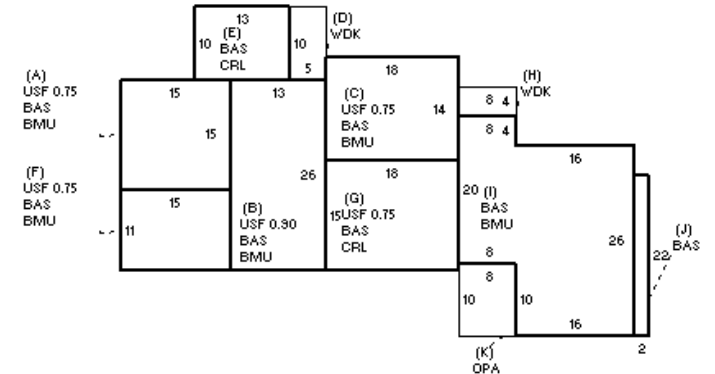

BUILDING

| BUILDING | CD | ADJ  | DESC            | MEASURE | 2/6/2008  | JH  |
|----------|----|------|-----------------|---------|-----------|-----|
| MODEL    | 1  |      | RESIDENTIAL     |         |           |     |
| STYLE    | 4  | 1.02 | CAPE [100%]     | LIST    | 7/30/2019 | NF  |
| QUALITY  | A  | 1.00 | AVG [100%]      | REVIEW  | 8/6/2019  | EMZ |
| FRAME    | 1  | 1.00 | WD FRAME [100%] |         |           |     |

BLDG COMMENTS  
2 HATCHES TO ATTIC - OLD SECTION & NEW SECTION

LOADING

| YEAR BLT      | 1981  | SIZE ADJ   | 0.990    |
|---------------|-------|------------|----------|
| NET AREA      | 2,988 | DETAIL ADJ | 1.000    |
| \$NLA(RCN)    | \$256 | OVERALL    | 1.030    |
| CAPACITY      |       | UNITS      | ADJ      |
| STORIES       |       | 1.75       | 1.00     |
| ROOMS         |       | 9          | 1.00     |
| BEDROOMS      |       | 3          | 1.00     |
| BATHROOMS     |       | 2          | 1.00     |
| FIXTURES      |       | 8          | \$10,712 |
| GARAGE SPACES |       | 0          | 1.00     |
| % BSMT FIN    |       | 19         | 1.00     |
| # 1/2 BATHS   |       | 1          | 1.00     |
| # OF UNITS    |       | 1          | 1.00     |

| ELEMENT      | CD | DESCRIPTION  | ADJ  | S | BAT | T | DESCRIPTION     | UNITS | YB   | ADJ PRICE | RCN     |
|--------------|----|--------------|------|---|-----|---|-----------------|-------|------|-----------|---------|
| FOUNDATION   | 4  | FLR & WALL   | 1.00 | + | BMU | N | BSMT UNFINISHED | 1,556 |      | 53.66     | 83,502  |
| EXT COVER    | 1  | WD SHINGLE   | 1.00 | + | BAS | L | BASE AREA       | 1,380 | 1981 | 231.25    | 319,121 |
| ROOF SHAPE   | 1  | GABLE        | 1.00 | + | USF | L | UPPER STORY FIN | 988   | 1981 | 185.56    | 183,330 |
| ROOF COVER   | 1  | ASPH/CMP SH  | 1.00 | + | WDK | N | WOOD DECK       | 82    |      | 39.97     | 3,277   |
| FLOOR COVER  | 1  | HARDWOOD     | 1.00 | E | CRL | N | BSMT CRAWL      | 130   |      | 30.96     | 4,025   |
| INT FINISH   | 2  | DRYWALL      | 1.00 | G | CRL | N | BSMT CRAWL      | 270   |      | 30.96     | 8,360   |
| HEATING/COOL | 16 | FHA+DCTLS AC | 1.01 | + | BAS | L | BASE AREA       | 620   | 2017 | 231.25    | 143,374 |
| FUEL SOURCE  | 1  | OIL          | 1.00 | K | OPA | N | OPEN PORCH      | 80    |      | 50.99     | 4,079   |
|              |    |              |      |   | MST | O | MAS/METAL STACK | 1     |      | 5,126.00  | 5,126   |

| TOTAL RCN      | 764,906    |
|----------------|------------|
| CONDITION ELEM | CD         |
| EXTERIOR       | A          |
| INTERIOR       | A          |
| KITCHEN        | A          |
| BATHS          | A          |
| HEAT/ELEC      | A          |
| EFF.YR/AGE     | 1988 / 35  |
| COND           | 23 23 %    |
| FUNC           | 0          |
| ECON           | 0          |
| DEPR           | 23 % GD 77 |
| RCNLD          | \$589,000  |