

Key: 2683

Town of BREWSTER - Fiscal Year 2025

9/17/2024 2:15 pm SEQ #: 2.851

LEGALS

CURRENT OWNER		PARCEL ID		LOCATION	
MCGUIRE DOUGLAS J & HYDE-MCGUIRE BETTY L 153 RIDGEWOOD DRIVE BREWSTER, MA 02631		25-24-0		153 RIDGEWOOD DRIVE	
TRANSFER HISTORY		DOS	T	SALE PRICE	BK-PG (Cert)
MCGUIRE DOUGLAS J & GERARDI ANGELO		03/15/2005	QS	721,000	19616-085
STEELE BRUCE R & NANCY F		06/27/2000	QS	465,000	13097-096
		06/27/1991	QS	343,350	7587-321

CLASS	CLASS%	DESCRIPTION		BN ID	BN	CARD	
1010	100	SINGLE FAMILY			1	1st	1 of 1
PMT NO	PMT DT	TY	DESC	AMOUNT	INSP	BY	1st %
594	07/17/2013	7	ALTERATIONS	10,000	08/14/2014	RJM	100 100
603	07/17/2013	7	ALTERATIONS		07/30/2015	MR	100 100
541	10/03/2008	7	ALTERATIONS	5,000	03/20/2009	JH	100 100
NP		12	CYCLICAL NON		07/17/2007	JH	100 100
829	11/27/2006	2	ADD	8,000	12/29/2010	JH	100 100

LAND

CD	T	AC/SF/UN	Nbhd	St Ind	Infl	ADJ BASE	SAF	Topo	Lpi	VC	CREDIT AMT	ADJ VALUE				
100	S	60,000	12	1.00	12C	1.00	A	1.00	230,160	1.00	A	1.00	R05	1.05		318,510
300	A	0.023	12	1.00	12C	1.00	A	1.00	12,600	1.00	A	1.00	R05	1.05		290

TOTAL	1.400 Acres	ZONING	RM	FRNT	0	ASSESSED	CURRENT	PREVIOUS
Nbhd	NBHD 12	NOTE	LAND	318,800	300,800			
St Ind	RIDGEWOOD		BUILDING	1,063,800	1,016,900			
Infl	AVERAGE		DETACHED	2,800	2,800			
			OTHER	0	0			
			TOTAL	1,385,400	1,320,500			

DETACHED

TY	QUAL	COND	DIM/NOTE	YB	UNITS	ADJ PRICE	RCNLD
SHF	A	1.00	30 0.70 16X12	1990	192	20.77	2,800

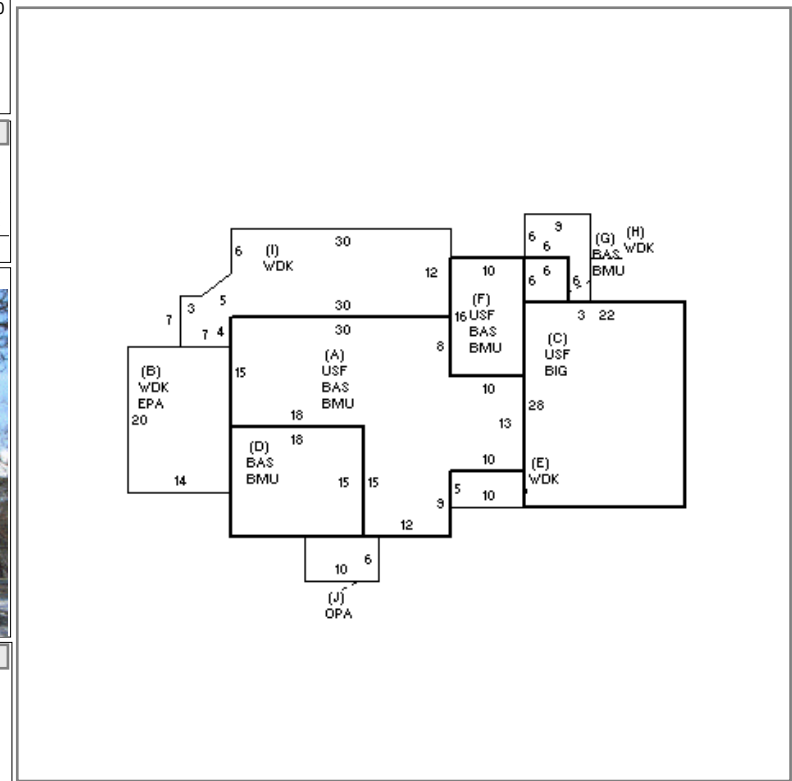

BUILDING

BUILDING	CD	ADJ	DESC	MEASURE	1/16/2018	NF
MODEL	1		RESIDENTIAL	LIST	7/17/2007	JH
STYLE	5	1.05	COLONIAL [100%]	REVIEW	12/16/2019	MR
QUALITY	V	1.65	VERY GOOD [100%]			
FRAME	1	1.00	WD FRAME [100%]			

BLDG COMMENTS  
24SOLAR PANELS

G

YEAR BLT	1990	SIZE ADJ	0.990	ELEMENT	CD	DESCRIPTION	ADJ	S	BAT	T	DESCRIPTION	UNITS	YB	ADJ PRICE	RCN	TOTAL RCN	1,313,326
NET AREA	2,762	DETAIL ADJ	1.000	FOUNDATION	4	FLR & WALL	1.00	+	BMU	N	BSMT UNFINISHED	1,226		98.53	120,794	CONDITION ELEM	CD
\$NLA(RCN)	\$476	OVERALL	1.110	EXT COVER	1	WD SHINGLE	1.00	A	BAS	L	BASE AREA	760	1990	446.95	339,682	EXTERIOR	A
				ROOF SHAPE	1	GABLE	1.00	+	USF	L	UPPER STORY FIN	1,376	1990	292.53	402,523	INTERIOR	A
				ROOF COVER	2	WD SHINGLE	1.01	B	EPA	N	ENCLOSED PORCH	280		131.37	36,782	KITCHEN	G
				FLOOR COVER	1	HARDWOOD	1.00	C	BIG	N	BUILT-IN GARAGE	616		86.23	53,119	BATHS	A
				INT FINISH	2	DRYWALL	1.00	D	BAS	L	BASE AREA	270	1990	446.95	120,677	HEAT/ELEC	A
				HEATING/COOL	11	HTWT/CL AIR	1.05	+	WDK	N	WOOD DECK	817		71.08	58,069		
				FUEL SOURCE	1	OIL	1.00	+	BAS	L	BASE AREA	196	2006	446.95	87,602		
								F	USF	L	UPPER STORY FIN	160	2006	292.54	46,806		
								J	OPA	N	OPEN PORCH	60		90.66	5,440		
								F21	O	FPL 2S 1OP	1		18,405.60	18,406			
								ODS	O	OUTDOOR SHOWER	1		4,378.80	4,379			
												EFF.YR/AGE	1995 / 28				
												COND	19 19%				
												FUNC	0				
												ECON	0				
												DEPR	19 % GD		81		
												RCNLD			\$1,063,800		