

Key: 2698

Town of BREWSTER - Fiscal Year 2025

9/17/2024 2:15 pm SEQ #: 2.866

LEG
AL
LAND

CURRENT OWNER		PARCEL ID		LOCATION	
PETRICHKO ROBERT J & LESLIE B 53 BRIER LANE BREWSTER, MA 02631		48-5-0		53 BRIER LANE	
TRANSFER HISTORY		DOS	T	SALE PRICE	BK-PG (Cert)
PETRICHKO ROBERT J & LESL		03/05/2021	O	820,000	33860-248
TRIPP MARTHA A		04/29/2002	QS	385,000	15098-119
ROBERTS SALLY		11/07/2000	DC		8381-319

CLASS	CLASS%	DESCRIPTION		BN ID	BN	CARD	
1010	100	SINGLE FAMILY			1	1 of 1	
PMT NO	PMT DT	TY	DESC	AMOUNT	INSP	BY	1st %
22-924	11/03/2022	2	ADD	55,000	05/07/2024	NF	100 100
921	10/06/2021	7	ALTERATIONS	21,000	05/11/2022	TCK	100 100
777	08/24/2021	7	ALTERATIONS	2,567	05/11/2022	TCK	100 100
724	08/10/2021	7	ALTERATIONS	32,000	05/11/2022	TCK	100 100
507	06/02/2021	3	OUT BUILDING	3,700	05/11/2022	TCK	100 100

CD	T	AC/SF/UN	Nbhd	St Ind	Infl	ADJ BASE	SAF	Topo	Lpi	VC	CREDIT AMT	ADJ VALUE				
100	S	60,000	11	1.00	A	1.00	A	1.00	372,640	1.00	A	1.00	R07	1.70		515,690
300	A	0.823	11	1.00	A	1.00	A	1.00	20,400	1.00	A	1.00	R07	1.70		16,790

TOTAL	2.200 Acres	ZONING	RM	FRNT	0	ASSESSED	CURRENT	PREVIOUS
Nbhd	NBHD 11	NOTE	LAND	532,500	502,300			
St Ind	AVERAGE		BUILDING	636,000	561,400			
Infl	AVERAGE		DETACHED	3,700	3,600			
			OTHER	0	0			
			TOTAL	1,172,200	1,067,300			

TY	QUAL	COND	DIM/NOTE	YB	UNITS	ADJ PRICE	RCNLD
SHF	A	1.00	40 0.60 7X12		84	22.01	1,100
SHF	A	1.00	01 1.00 10X12	2021	120	21.39	2,600

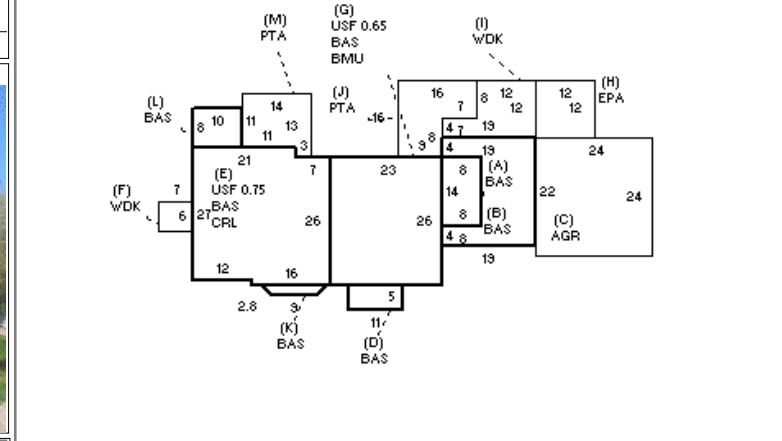

BLDG COMMENTS	INFO @ DOOR (2/16/2021)
---------------	-------------------------

DET
ACHED

B
U
I
L
D
I
N
G

YEAR BLT	1920	SIZE ADJ	0.990	ELEMENT	CD	DESCRIPTION	ADJ	S	BAT	T	DESCRIPTION	UNITS	YB	ADJ PRICE	RCN	TOTAL RCN	859,445		
NET AREA	2,888	DETAIL ADJ	1.000	FOUNDATION	4	FLR & WALL	1.00	+	BAS	L	BASE AREA	1,851	1920	261.78	484,557	CONDITION ELEM	CD		
\$NLA(RCN)	\$298	OVERALL	1.060	EXT COVER	1	WD SHINGLE	1.00	C	AGR	N	ATT GARAGE	576		43.78	25,219	EXTERIOR	V		
				ROOF SHAPE	1	GABLE	1.00	E	CRL	N	BSMT CRAWL	758		32.67	24,763	INTERIOR	G		
				ROOF COVER	1	ASPH/CMP SH	1.00	+	USF	L	UPPER STORY FIN	957	1920	210.06	201,025	KITCHEN	V		
				FLOOR COVER	1	HARDWOOD	1.00	+	WDK	N	WOOD DECK	214		45.25	9,684	BATHS	V		
				INT FINISH	2	DRYWALL	1.00	G	BMU	N	BSMT UNFINISHED	598		77.17	46,145	HEAT/ELEC	A		
				HEATING/COOL	15	HTWT+DCTLS AC	1.01	H	EPA	N	ENCLOSED PORCH	144		92.92	13,381				
				FUEL SOURCE	2	GAS	1.00	J	PTA	N	PATIO	200		17.44	3,487				
								L	BAS	L	BASE AREA	80	2023	261.78	20,942				
								M	PTA	N	PATIO	160		17.44	2,790				
								F21	O	FPL 2S 1OP	1		11,717.70	11,718					
								GFP	O	GAS FIREPLACE	1		3,608.50	3,609					
												EFF.YR/AGE	1981 / 42						
												COND	26 26 %						
												FUNC	0						
												ECON	0						
												DEPR	26 % GD		74				
												RCNLD			\$636,000				