

Key: 2701

Town of BREWSTER - Fiscal Year 2025

9/17/2024 2:15 pm SEQ #: 2.869

LEG
AL
LAND

CURRENT OWNER				PARCEL ID				LOCATION			
RANSCHT WILLIAM F JR & NANCY H 85 BRIER LANE BREWSTER, MA 02631				48-8-0				85 BRIER LANE			
TRANSFER HISTORY				DOS	T	SALE PRICE	BK-PG (Cert)				
RANSCHT WILLIAM F JR & NA				12/01/1999	J	273,500	12697-258				
O'RIORDAN DELIA D				06/30/1998	A	100	11536-337				
O RIORDAN JOHN & DELIA D				02/13/1987	XX		5559-48				

CLASS	CLASS%	DESCRIPTION			BN ID	BN	CARD	
1010	100	SINGLE FAMILY				1	1 of 1	
PMT NO	PMT DT	TY	DESC	AMOUNT	INSP	BY	1st	%
24-5	01/09/2024	1	NEW CONSTRUC	7,693				0
857	11/13/2012	7	ALTERATIONS	8,600	02/04/2013	SF	100	100
43	01/23/2001	3	OUT BUILDING	1,200	12/03/2007	JH	100	100

LAND

CD	T	AC/SF/UN	Nbhd	St Ind	Infl	ADJ BASE	SAF	Topo	Lpi	VC	CREDIT AMT	ADJ VALUE
100	S	27,124	11	1.00	A	1.00	A	1.00				404,160

TOTAL	27,124 SF	ZONING	RM	FRNT	0	ASSESSED	CURRENT	PREVIOUS
Nbhd	NBHD 11	NOTE				LAND	404,200	381,300
St Ind	AVERAGE		BUILDING	429,700	411,300			
Infl	AVERAGE		DETACHED	1,100	1,100			
			OTHER	0	0			
			TOTAL	835,000	793,700			

DETACHED

TY	QUAL	COND	DIM/NOTE	YB	UNITS	ADJ PRICE	RCNLD
SHF	A	1.00	20 0.80 8X8	2001	64	22.01	1,100

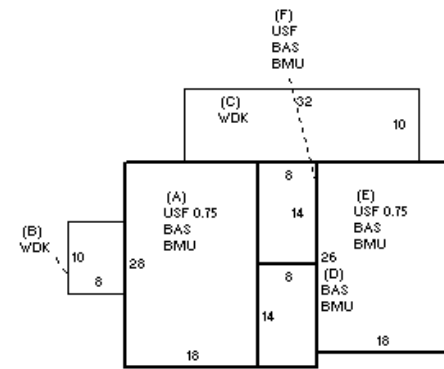

BUILDING

BUILDING	CD	ADJ	DESC	MEASURE	2/16/2021	NF
MODEL	1		RESIDENTIAL	LIST	2/16/2021	EST
STYLE	4	1.02	CAPE [100%]	REVIEW	3/8/2021	MR
QUALITY	A	1.00	AVG [100%]			
FRAME	1	1.00	WD FRAME [100%]			

BLDG COMMENTS
INFO @ DOOR (2/16/2021)

INDING

YEAR BLT	1984	SIZE ADJ	1.000	ELEMENT	CD	DESCRIPTION	ADJ	S	BAT	T	DESCRIPTION	UNITS	YB	ADJ PRICE	RCN	TOTAL RCN	572,992		
NET AREA	2,037	DETAIL ADJ	1.000	FOUNDATION	4	FLR & WALL	1.00	+	BMU	N	BSMT UNFINISHED	1,196		57.59	68,881	CONDITION ELEM	CD		
\$NLA(RCN)	\$281	OVERALL	1.020	EXT COVER	1	WD SHINGLE	1.00	+	BAS	L	BASE AREA	1,196	1984	258.97	309,731	EXTERIOR	A		
				ROOF SHAPE	1	GABLE	1.00	+	USF	L	UPPER STORY FIN	841	1984	185.61	156,099	INTERIOR	A		
				ROOF COVER	1	ASPH/CMP SH	1.00	+	WDK	N	WOOD DECK	400		39.98	15,994	KITCHEN	A		
				FLOOR COVER	1	HARDWOOD	1.00		F21	O	FPL 2S 1OP	1		10,354.00	10,354	BATHS	A		
				INT FINISH	2	DRYWALL	1.00									HEAT/ELEC	A		
				HEATING/COOL	2	HOT WATER	1.00												
				FUEL SOURCE	1	OIL	1.00												
																		EFF.YR/AGE	1984 / 39
																		COND	25 25 %
																		FUNC	0
																		ECON	0
																		DEPR	25 % GD 75
																		RCNLD	\$429,700