

Key: 2714

Town of BREWSTER - Fiscal Year 2025

9/17/2024 2:15 pm SEQ #: 2.887

LEGAL

LAND

DETACHED

BUILDING

CURRENT OWNER		PARCEL ID		LOCATION	
MCKELVEY BERKE & MARILEE 1311 MAIN STREET BREWSTER, MA 02631		47-18-0		1311 MAIN STREET	
TRANSFER HISTORY		DOS	T	SALE PRICE	BK-PG (Cert)
MCKELVEY BERKE & MARILEE		06/03/2000	QS	325,000	13062-213
WOOD ALICE M TRUSTEE		04/01/1991	XX		7482-249

CLASS	CLASS%	DESCRIPTION		BN ID	BN	CARD	
1010	100	SINGLE FAMILY			1	1 of 1	
PMT NO	PMT DT	TY	DESC	AMOUNT	INSP	BY	1st %
492	05/28/2021	7	ALTERATIONS	3,886	05/17/2022	TCK	100 100
850	11/08/2012	7	ALTERATIONS	6,475	02/12/2013	SF	100 100
557	10/17/2008	7	ALTERATIONS	2,200	04/02/2009	JH	100 100
315	05/17/2006	7	ALTERATIONS	6,000	07/30/2007	RJM	100 100
746	12/12/2005	2	ADD	120,000	04/02/2009	JH	100 100

CD	T	AC/SF/UN	Nbhd	St Ind	Infl	ADJ BASE	SAF	Topo	Lpi	VC	CREDIT AMT	ADJ VALUE					
100	S	60,000	10	1.00	A	1.00	A	1.00	219,200	1.00	A	1.00	R03	1.00			303,350
300	A	0.073	10	1.00	A	1.00	A	1.00	12,000	1.00	A	1.00	R03	1.00			880

TOTAL	1.450 Acres	ZONING	RM	FRNT	0	ASSESSED	CURRENT	PREVIOUS
Nbhd	NBHD 10	NOTE				LAND	304,200	287,000
St Ind	AVERAGE		BUILDING	504,400	476,400			
Infl	AVERAGE		DETACHED	0	0			
			OTHER	0	0			
						TOTAL	808,600	763,400

TY	QUAL	COND	DIM/NOTE	YB	UNITS	ADJ PRICE	RCNLD

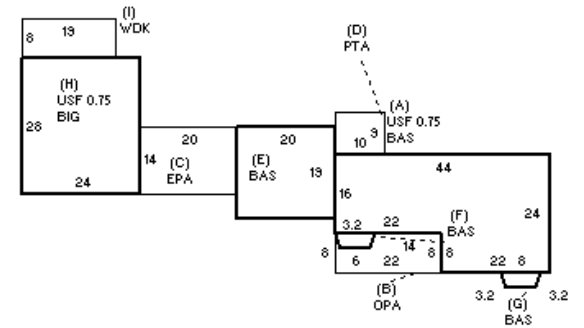

BUILDING	CD	ADJ	DESC	MEASURE	12/27/2017	NF
MODEL	1		RESIDENTIAL	LIST	7/30/2007	RJM
STYLE	7	1.05	CONVEN/OLD [100%]	REVIEW	5/27/2022	MR
QUALITY	G	1.30	GOOD [100%]			
FRAME	1	1.00	WD FRAME [100%]			

BLDG COMMENTS  
APT(4-2-1) OVER BIG

YEAR BLT	1840	SIZE ADJ	1.000	ELEMENT	CD	DESCRIPTION	ADJ	S	BAT	T	DESCRIPTION	UNITS	YB	ADJ PRICE	RCN	TOTAL RCN	788,154
NET AREA	2,466	DETAIL ADJ	0.950	FOUNDATION	5	OTHER	1.00	+	BAS	L	BASE AREA	1,302	1840	319.65	416,183	CONDITION ELEM	CD
\$NLA(RCN)	\$320	OVERALL	1.050	EXT COVER	1	WD SHINGLE	1.00	A	USF	L	UPPER STORY FIN	660	1840	228.67	150,925	EXTERIOR	A
				ROOF SHAPE	1	GABLE	1.00	B	OPA	N	OPEN PORCH	155		64.84	10,051	INTERIOR	A
				ROOF COVER	1	ASPH/CMP SH	1.00	C	EPA	N	ENCLOSED PORCH	280		93.95	26,306	KITCHEN	A
				FLOOR COVER	2	SOFTWOOD	1.00	D	PTA	N	PATIO	90		23.71	2,134	BATHS	G
				INT FINISH	1	PLASTER	1.00	H	BIG	N	BUILT-IN GARAGE	672		61.67	41,443	HEAT/ELEC	G
				HEATING/COOL	2	HOT WATER	1.00	H	USF	L	UPPER STORY FIN	504	2006	228.68	115,252		
				FUEL SOURCE	2	GAS	1.00	I	WDK	N	WOOD DECK	152		50.83	7,726		
									KIT	O	XTRA KITCHEN	1		2,962.10	2,962		
																EFF.YR/AGE	1961 / 62
																COND	36 36 %
																FUNC	0
																ECON	0
																DEPR	36 % GD 64
																RCNLD	\$504,400