

Key: 2793

Town of BREWSTER - Fiscal Year 2025

9/17/2024 2:15 pm SEQ #: 2.960

LEG  
A  
L  
L  
A  
N  
D

CURRENT OWNER				PARCEL ID				LOCATION			
SUPERIOR HOTEL MANAGEMENT CORP C/O WOOL JARS LLC 716 MAIN STREET BREWSTER, MA 02631				48-79-0				1573-1577 MAIN STREET			
TRANSFER HISTORY				DOS	T	SALE PRICE	BK-PG (Cert)				
WOOL JARS LLC				04/19/2024	QS	1,250,000	36322-1				
SUPERIOR HOTEL MANAGEMENT				07/03/2019	QS	830,000	32137-228				
SCHOOLHOUSE LTD PARTNERSH				02/06/2002	F	100	14790-162				

CLASS	CLASS%	DESCRIPTION			BN ID	BN	CARD	
3400	100	GEN OFFICE BLDG				1	1 of 2	
PMT NO	PMT DT	TY	DESC	AMOUNT	INSP	BY	1st	%
67	01/28/2022	7	ALTERATIONS	278,050	07/21/2023	PJK	100	100
738	10/23/2020	7	ALTERATIONS	25,000	02/04/2021	PJK	100	100
	04/17/2020	22	I & E				0	0
561	06/14/2019	7	ALTERATIONS	15,000	07/08/2020	PJK	100	100
573	07/24/2017	7	ALTERATIONS	12,260	07/02/2018	PJK	100	100

CD	T	AC/SF/UN	Nbhd	St Ind	Infl	ADJ BASE	SAF	Topo	Lpi	VC	CREDIT AMT	ADJ VALUE
103	S	40,000	CIM	1.00	37	1.00	A	1.00				296,050
303	A	0.142	CIM	1.00	37	1.00	A	1.00				2,020

TOTAL	1.060 Acres	ZONING	RM	FRNT	0	ASSESSED	CURRENT	PREVIOUS
Nbhd	CIM	N O T E				LAND	298,100	286,600
St Ind	PAINES-SACHEM		LAND	718,300	616,300			
Infl	AVERAGE		DETACHED	28,300	28,300			
			OTHER	0	0			
						<b>TOTAL</b>	<b>1,044,700</b>	<b>931,200</b>

TY	QUAL	COND	DIM/NOTE	YB	UNITS	ADJ PRICE	RCNLD
PAV	A	1.00	50 0.50		25,730	2.20	28,300



BLDG COMMENTS  
 BENNETT ENVIROMENTAL/O'REILLY ASSOC/WELL BODY/MICHAEL SINGLETON DC

\* -- Partial Listing. See Next Page.

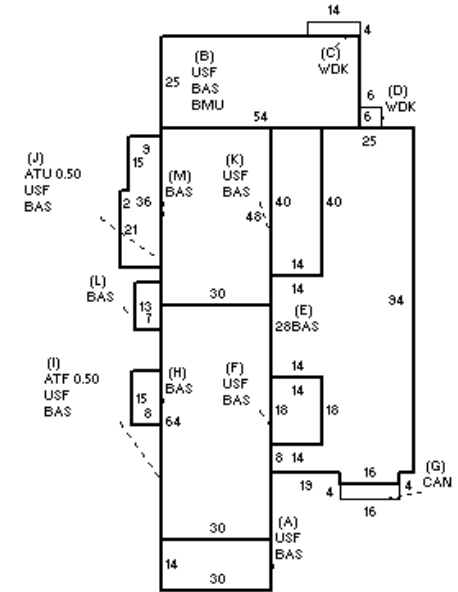

D  
E  
T  
A  
C  
H  
E  
D

BUILDING	CD	ADJ	DESC	MEASURE	3/31/2008	JH
MODEL	6		CIM-6	LIST	3/31/2008	JH
STYLE	20	1.25	OFFICE BUILDING [100%]	REVIEW	5/8/2008	ER
QUALITY	A	1.00	AVG [100%]			
FRAME	1	1.00	WOOD FRAME [100%]			

B  
U  
I  
L  
D  
I  
N  
G

YEAR BLT	1880	SIZE ADJ	0.920	ELEMENT	CD	DESCRIPTION	ADJ	S	BAT	T	DESCRIPTION *	UNITS	YB	ADJ PRICE	RCN	TOTAL RCN	997,666
NET AREA	16,323	DETAIL ADJ	1.164	FOUNDATION	4	FLR & WALL	1.00	A	BAS	L	BAS AREA	420	1880	61.09	25,656	CONDITION ELEM	CD
\$NLA(RCN)	\$61	OVERALL	1.015	EXT. COVER	1	WOOD SHINGLE	1.00	A	USF	L	UP-STRY FIN	420	1880	61.09	25,656	EXTERIOR	G
				ROOF SHAPE	1	GABLE	1.00	B	BMU	N	BSMT UNF	1,350		21.41	28,907	INTERIOR	G
				ROOF COVER	1	ASPH/CMP SHNGL	1.00	B	BAS	L	BAS AREA	1,350	1880	61.09	82,467		
				FLOOR COVER	2	SOFTWOOD	0.95	B	USF	L	UP-STRY FIN	1,350	1880	61.09	82,467		
				INT. FINISH	2	DRYWALL	1.00	C	WDK	N	WOOD DECK	56		17.62	987		
				HEATING/COOL	2	HOT WATER	1.02	D	WDK	N	WOOD DECK	36		17.62	634		
				FUEL SOURCE	2	GAS	1.00	E	BAS	L	BAS AREA	2,902	1880	61.09	177,272		
								F	BAS	L	BAS AREA	252	1880	61.09	15,394		
								F	USF	L	UP-STRY FIN	252	1880	61.09	15,394		
								G	CAN	N	CANOPY	64		18.37	1,175		
								H	BAS	L	BAS AREA	120	1880	61.09	7,330		
								I	BAS	L	BAS AREA	1,920	1880	61.09	117,285		
								I	USF	L	UP-STRY FIN	1,920	1880	61.09	117,285		
								I	ATF	L	ATTIC FIN	960	1880	15.22	14,609		
								J	BAS	L	BAS AREA	1,440	1880	61.09	87,964		
																EFF. YR/AGE	1988 / 35
																COND	28 28 %
																FUNC	0
																ECON	0
																DEPR	28 % GD 72
																RCNLD	\$718,300

Key: 2793

Town of BREWSTER - Fiscal Year 2025

9/17/2024 2:15 pm SEQ #: 2.961

LEGAL

CURRENT OWNER				PARCEL ID				LOCATION			
SUPERIOR HOTEL MANAGEMENT CORP C/O WOOL JARS LLC 716 MAIN STREET BREWSTER, MA 02631				48-79-0				1573-1577 MAIN STREET			
TRANSFER HISTORY				DOS	T	SALE PRICE	BK-PG (Cert)				

CLASS	CLASS%	DESCRIPTION			BN ID	BN	CARD	
3400	100	GEN OFFICE BLDG				1	2 of 2	
PMT NO	PMT DT	TY	DESC	AMOUNT	INSP	BY	1st	%

LAND

CD	T	AC/SF/UN	Nbhd	St Ind	Infl	ADJ BASE	SAF	Topo	Lpi	VC	CREDIT AMT	ADJ VALUE
----	---	----------	------	--------	------	----------	-----	------	-----	----	------------	-----------

\* -- Partial Listing. See Previous Page.

TOTAL	ZONING	FRNT	ASSESSED	CURRENT	PREVIOUS
Nbhd	NOTE		LAND		
St Ind			BUILDING		
Infl			DETACHED		
			OTHER		
			TOTAL		

DETACHED

TY	QUAL	COND	DIM/NOTE	YB	UNITS	ADJ PRICE	RCNLD	PHOTO
----	------	------	----------	----	-------	-----------	-------	-------

BUILDING	CD	ADJ	DESC	MEASURE
MODEL				LIST
STYLE				REVIEW
QUALITY				
FRAME				

BUILDING

YEAR BLT	NET AREA	\$NLA(RCN)	SIZE ADJ	DETAIL ADJ	OVERALL	ELEMENT	CD	DESCRIPTION	ADJ	S	BAT	T	DESCRIPTION *	UNITS	YB	ADJ PRICE	RCN	TOTAL RCN	CONDITION ELEM	CD
										J	USF	L	UP-STRY FIN	1,440	1880	61.09	87,964			
										J	ATU	N	ATTIC UNF	720		6.09	4,383			
										K	BAS	L	BAS AREA	560	1880	61.09	34,209			
										K	USF	L	UP-STRY FIN	560	1880	61.09	34,209			
										L	BAS	L	BAS AREA	91	1880	61.09	5,559			
										M	BAS	L	BAS AREA	366	1880	61.09	22,357			
											BMG	O	BSMT GAR	3		2,834.57	8,504			
																		EFF.YR/AGE		
																		COND		
																		FUNC		
																		ECON		
																		DEPR		% GD
																		RCNLD		