

Key: 2898

Town of BREWSTER - Fiscal Year 2025

9/17/2024 2:15 pm SEQ #: 3.079

LEG
AL
LAND

CURRENT OWNER				PARCEL ID				LOCATION					
BARKER ZEBULUN J & SUSAN A 141 HARWICH ROAD BREWSTER, MA 02631				56-31-0				141 HARWICH ROAD					
TRANSFER HISTORY				DOS	T	SALE PRICE	BK-PG (Cert)						
BARKER ZEBULUN J & SUSAN				01/13/2017	A	477,500	30236-92						
HACKWORTH MICHAEL W & AMY				08/17/2016	QS	477,500	29866-209						
HANSEN KAREN B &				03/25/2011	F	1	25338-113						
CD	T	AC/SF/UN	Nbhd	St Ind	Infl	ADJ BASE	SAF	Topo	Lpi	VC	CREDIT AMT	ADJ VALUE	
100	S	38,983	12	1.00	12D 1.00	A	1.00	219,200	1.34	A	1.00	RM4 1.00	262,670

CLASS	CLASS%	DESCRIPTION			BN ID	BN	CARD	
1040	100	TWO FAMILY				1	1 of 1	
PMT NO	PMT DT	TY	DESC	AMOUNT	INSP	BY	1st	%
508	01/13/2017	16	MLS REVIEW	477,500	05/30/2018	JMG	100	100
578	08/25/2003	12	CYCLICAL NON		07/19/2004	JB	100	100
539	09/29/2000	2	ADD	30,000	07/19/2004	JB	100	100
	09/08/1994	1	NEW CONSTRUC	30,000	05/09/2001	LB	100	100
		2	ADD	5,000	01/01/1995	RD	100	100

DE
TA
CH
ED

TOTAL	38,986 SF	ZONING	RM	FRNT	0	ASSESSED	CURRENT	PREVIOUS
Nbhd	NBHD 12	NOTE				LAND	262,700	247,800
St Ind	HARWICH ROAD		BUILDING	592,100	559,300			
Infl	AVERAGE		DETACHED	2,300	2,300			
			OTHER	0	0			
						TOTAL	857,100	809,400

BU
IL
DING

TY	QUAL	COND	DIM/NOTE	YB	UNITS	ADJ PRICE	RCNLD
SHF	A	1.00	30 0.70	10X12	120	21.39	1,800
SHF	A	1.00	30 0.70	4X8	32	22.94	500

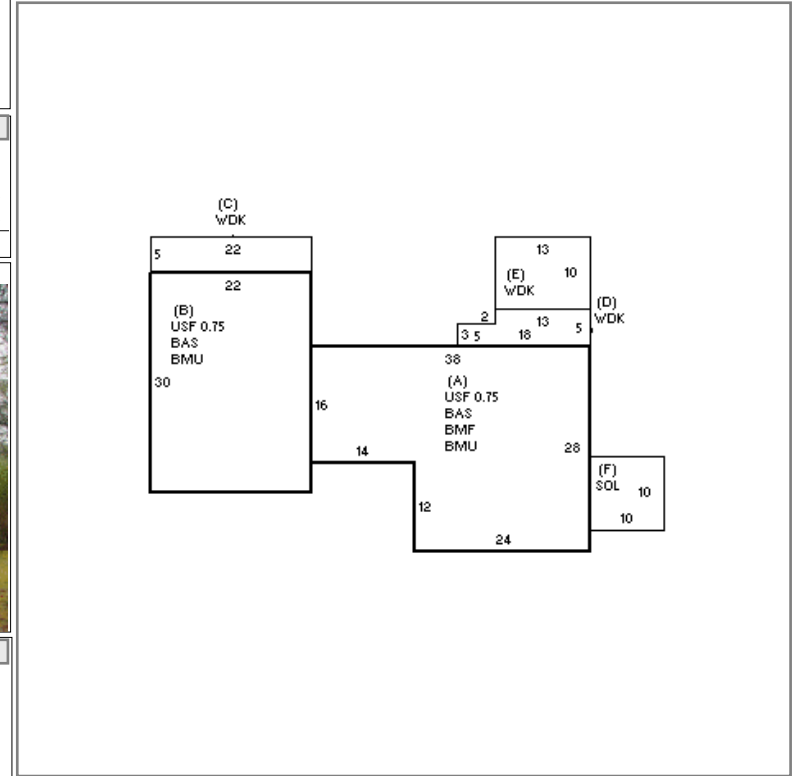

RE
VIEW

BUILDING	CD	ADJ	DESC	MEASURE	4/3/2019	NF
MODEL	1		RESIDENTIAL	LIST	4/3/2019	EST
STYLE	4	1.02	CAPE [100%]	REVIEW	12/27/2019	MR
QUALITY	A	1.00	AVG [100%]			
FRAME	1	1.00	WD FRAME [100%]			

BLDG COMMENTS

YEAR BLT	1978	SIZE ADJ	0.990
NET AREA	2,723	DETAIL ADJ	0.950
\$NLA(RCN)	\$268	OVERALL	1.020
CAPACITY		UNITS	ADJ
STORIES		1.75	1.00
ROOMS		9	1.00
BEDROOMS		4	1.00
BATHROOMS		4	1.00
FIXTURES		12	\$15,116
GARAGE SPACES		2	1.00
% BSMT FIN		75	1.00
# 1/2 BATHS		0	1.00
# OF UNITS		2	.95

ELEMENT	CD	DESCRIPTION	ADJ
FOUNDATION	4	FLR & WALL	1.00
EXT COVER	2	CLAPBOARD	1.00
ROOF SHAPE	1	GABLE	1.00
ROOF COVER	1	ASPH/CMP SH	1.00
FLOOR COVER	2	SOFTWOOD	1.00
INT FINISH	2	DRYWALL	1.00
HEATING/COOL	2	HOT WATER	1.00
FUEL SOURCE	1	OIL	1.00

S	BAT	T	DESCRIPTION	UNITS	YB	ADJ PRICE	RCN
+	BMU	N	BSMT UNFINISHED	1,556		53.14	82,692
A	BMF	N	BSMT FINISH	896		34.15	30,600
A	BAS	L	BASE AREA	896	1978	231.74	207,639
A	USF	L	UPPER STORY FIN	672	1978	169.17	113,681
B	BAS	L	BASE AREA	660	2000	231.74	152,948
B	USF	L	UPPER STORY FIN	495	2000	169.17	83,739
+	WDK	N	WOOD DECK	320		37.61	12,034
F	SOL	N	SOLARIUM	100		117.24	11,724
	BMG	O	BSMT GARAGE	2		2,967.80	5,936
	F21	O	FPL 2S 1OP	1		10,250.50	10,251
	KIT	O	XTRA KITCHEN	1		2,191.30	2,191
	ODS	O	OUTDOOR SHOWER	1		2,438.70	2,439

TOTAL RCN	730,989
CONDITION ELEM	CD
EXTERIOR	G
INTERIOR	A
KITCHEN	G
BATHS	A
HEAT/ELEC	A
EFF.YR/AGE	1995 / 28
COND	19 19 %
FUNC	0
ECON	0
DEPR	19 % GD 81
RCNLD	\$592,100