

Key: 320

Town of BREWSTER - Fiscal Year 2025

9/17/2024 2:15 pm SEQ #: 333

LEGALS

Table with columns: CURRENT OWNER, PARCEL ID, LOCATION, TRANSFER HISTORY, and various property details like ADJ BASE, SAF, Topo, Lpi, VC, CREDIT AMT, ADJ VALUE.

Table with columns: CLASS, CLASS%, DESCRIPTION, BN ID, BN, CARD, PMT NO, PMT DT, TY, DESC, AMOUNT, INSP, BY, 1st, %.

LAND

Table with columns: TOTAL, Nbhd, St Ind, Infl, ZONING, RM, FRNT, ASSESSED, CURRENT, PREVIOUS.

Table with columns: TY, QUAL, COND, DIM/NOTE, YB, UNITS, ADJ PRICE, RCNLD, PHOTO (10/08/2020).

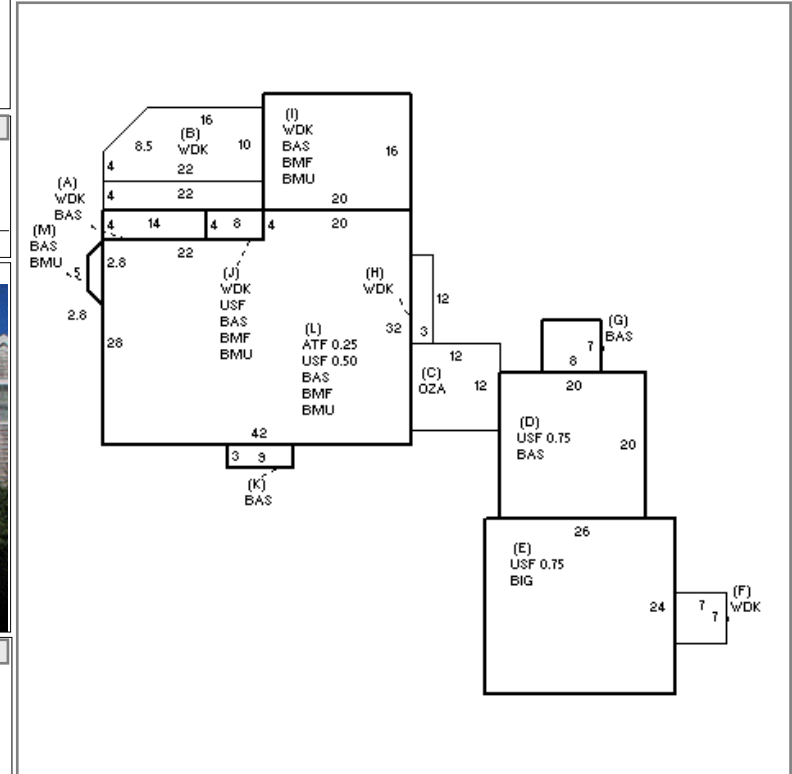

DETACHED

Table with columns: BUILDING, CD, ADJ, DESC, MEASURE, 10/8/2020, NF, LIST, 10/8/2020, EST, REVIEW, 1/15/2021, MR.

Table with columns: BLDG COMMENTS.

BUILDING

Table with columns: YEAR BLT, SIZE ADJ, NET AREA, \$NLA(RCN), CAPACITY, UNITS, ADJ, and various room counts like STORIES, ROOMS, BEDROOMS, BATHROOMS, etc.

Table with columns: ELEMENT, CD, DESCRIPTION, ADJ, S, BAT, T, DESCRIPTION, UNITS, YB, ADJ PRICE, RCN.

Table with columns: S, BAT, T, DESCRIPTION, UNITS, YB, ADJ PRICE, RCN, and various building details like FOUNDATION, EXT COVER, ROOF SHAPE, etc.

Table with columns: TOTAL RCN, CONDITION ELEM, CD, EFF. YR/AGE, COND, FUNC, ECON, DEPR, RCNLD.