

Key: 3504

Town of BREWSTER - Fiscal Year 2025

9/17/2024 2:15 pm SEQ #: 3.715

LEG
A
L

L
A
N
D

CURRENT OWNER				PARCEL ID				LOCATION				
VON THADEN HARRY & HARRIET TRSTEEES 70 OLD HAVERSTRAW ROAD CONGERS, NY 10920				88-26-0				10 SOUTH POND DRIVE				
TRANSFER HISTORY				DOS	T	SALE PRICE		BK-PG (Cert)				
VON THADEN HARRY & HARRIE				05/17/2016	F	10 29654-250		7009-178				
VON THADEN HARRY				12/29/1989	F	100 7009-178						
HARRY VON THADEN				08/17/1989	L	80,000 N/A-N/A						
CD	T	AC/SF/UN	Nbhd	St Ind	Infl	ADJ BASE	SAF	Topo	Lpi	VC	CREDIT AMT	ADJ VALUE
100	S	27,870	13	1.00	13M 1.00	A 1.00	252,080	1.71	A	1.00	R04 1.15	275,370

CLASS	CLASS%	DESCRIPTION			BN ID	BN	CARD	
1010	100	SINGLE FAMILY				1	1 of 1	
PMT NO	PMT DT	TY	DESC	AMOUNT	INSP	BY	1st	%
744	10/26/2020	14	CYCLICAL GRO		12/29/2020	TCK	100	100
NP		7	ALTERATIONS	5,000	12/29/2020	TCK	100	100
538	12/24/2009	12	CYCLICAL NON		01/06/2011	JH	100	100
		2	ADD	25,000	01/06/2011	JH	100	100
		12	CYCLICAL NON		02/24/2004	JB	100	100

TOTAL	27,870 SF	ZONING	RM	FRNT	0	ASSESSED	CURRENT	PREVIOUS
Nbhd	NBHD 13	NOTE				LAND	275,400	259,800
St Ind	LUND FARM		BUILDING	297,400	280,900			
Infl	AVERAGE		DETACHED	0	0			
			OTHER	0	0			
						TOTAL	572,800	540,700

TY	QUAL	COND	DIM/NOTE	YB	UNITS	ADJ PRICE	RCNLD

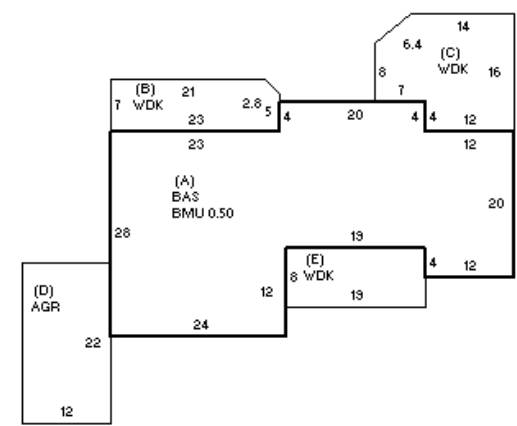

BLDG COMMENTS

D
E
T
A
C
H
E
D

BUILDING	CD	ADJ	DESC	MEASURE	12/29/2020	TCK
MODEL	1		RESIDENTIAL	LIST	12/29/2020	EST
STYLE	8	0.95	CONTEMPOR [100%]	REVIEW	2/16/2021	MR
QUALITY	+	1.10	PLUS AVE [100%]			
FRAME	1	1.00	WD FRAME [100%]			

B
U
I
L
D
I
N
G

YEAR BLT	1969	SIZE ADJ	1.000	ELEMENT	CD	DESCRIPTION	ADJ	S	BAT	T	DESCRIPTION	UNITS	YB	ADJ PRICE	RCN	TOTAL RCN	437,394		
NET AREA	1,296	DETAIL ADJ	1.000	FOUNDATION	4	FLR & WALL	1.00	A	BMU	N	BSMT UNFINISHED	648		65.79	42,634	CONDITION ELEM	CD		
\$NLA(RCN)	\$338	OVERALL	0.960	EXT COVER	1	WD SHINGLE	1.00	A	BAS	L	BASE AREA	1,296	1969	260.30	337,354	EXTERIOR	A		
				ROOF SHAPE	1	GABLE	1.00	+	WDK	N	WOOD DECK	577		41.39	23,885	INTERIOR	A		
				ROOF COVER	1	ASPH/CMP SH	1.00	D	AGR	N	ATT GARAGE	264		45.51	12,015	KITCHEN	A		
				FLOOR COVER	2	SOFTWOOD	1.00		F21	O	FPL 2S 1OP	1		10,719.50	10,720	BATHS	A		
				INT FINISH	2	DRYWALL	1.00		ODS	O	OUTDOOR SHOWER	1		2,550.20	2,550	HEAT/ELEC	A		
				HEATING/COOL	16	FHA+DCTLS AC	1.01												
				FUEL SOURCE	1	OIL	1.00												
CAPACITY		UNITS	ADJ															EFF.YR/AGE	1969 / 54
STORIES		1.75	1.00															COND	32 32 %
ROOMS		6	1.00															FUNC	0
BEDROOMS		3	1.00															ECON	0
BATHROOMS		2	1.00															DEPR	32 % GD 68
FIXTURES		6	\$8,237															RCNLD	\$297,400
GARAGE SPACES		0	1.00																
% BSMT FIN		0	1.00																
# 1/2 BATHS		0	1.00																
# OF UNITS		1	1.00																