

Key: 3510

Town of BREWSTER - Fiscal Year 2025

9/17/2024 2:15 pm SEQ #: 3.721

LEG
AL
LAND

CURRENT OWNER				PARCEL ID				LOCATION				
LINCOLN BARBARA TYLER 100 SOUTH POND DRIVE BREWSTER, MA 02631				88-20-0				100 SOUTH POND DRIVE				
TRANSFER HISTORY				DOS		T		SALE PRICE		BK-PG (Cert)		
LINCOLN BARBARA TYLER				06/30/2006		QS		374,000		21149-168		
L'ETOILE NANCY A & GENE J				04/06/2001		F		1 13705-177				
L'ETOILE GENE J & NANCY A				09/27/1996		QS		130,000		10410-318		
CD	T	AC/SF/UN	Nbhd	St Ind	Infl	ADJ BASE	SAF	Topo	Lpi	VC	CREDIT AMT	ADJ VALUE
100	S	21,150	13	1.00	13M 1.00	A	1.00					281,800

CLASS	CLASS%	DESCRIPTION			BN ID	BN	CARD	
1010	100	SINGLE FAMILY				1	1 of 1	
PMT NO	PMT DT	TY	DESC	AMOUNT	INSP	BY	1st	%
1101	12/26/2013	7	ALTERATIONS	24,300	08/18/2014	RJM	100	100
JH	08/04/2006	12	CYCLICAL NON	3,300	04/24/2013	SF	100	100
		3	OUT BUILDING		08/01/2007	JH	100	100

LAND

TOTAL	21,170 SF	ZONING	RL	FRNT	0	ASSESSED	CURRENT	PREVIOUS
Nbhd	NBHD 13	N O T E	POND VIEW			LAND	281,800	265,900
St Ind	LUND FARM		LAND	324,900	306,800			
Infl	AVERAGE		DETACHED	2,600	2,600			
			OTHER	0	0			
TOTAL						609,300	575,300	

DET
ACHED

TY	QUAL	COND	DIM/NOTE	YB	UNITS	ADJ PRICE	RCNLD
SHF	A	1.00	15 0.85 12X12	2006	144	21.39	2,600

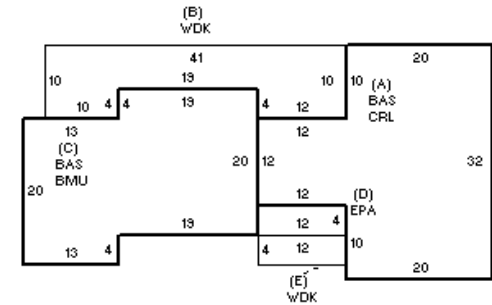

B
U
I
L
D
I
N
G

BUILDING	CD	ADJ	DESC	MEASURE	12/30/2020	TCK
MODEL	1		RESIDENTIAL	LIST	4/24/2013	SF
STYLE	1	1.00	RANCH [100%]	REVIEW	2/16/2021	MR
QUALITY	A	1.00	AVG [100%]			
FRAME	1	1.00	WD FRAME [100%]			

BLDG COMMENTS
INFO @ DOOR (12/30/20)

YEAR BLT	1969	SIZE ADJ	1.000	ELEMENT	CD	DESCRIPTION	ADJ	S	BAT	T	DESCRIPTION	UNITS	YB	ADJ PRICE	RCN	TOTAL RCN	464,177		
NET AREA	1,424	DETAIL ADJ	1.000	FOUNDATION	4	FLR & WALL	1.00	A	CRL	N	BSMT CRAWL	784		29.72	23,297	CONDITION ELEM	CD		
\$NLA(RCN)	\$326	OVERALL	1.050	EXT COVER	1	WD SHINGLE	1.00	A	BAS	L	BASE AREA	784	1969	253.65	198,861	EXTERIOR	G		
				ROOF SHAPE	4	FLAT/SHED	1.00	+	WDK	N	WOOD DECK	382		41.16	15,723	INTERIOR	A		
				ROOF COVER	1	ASPH/CMP SH	1.00	C	BMU	N	BSMT UNFINISHED	640		65.42	41,869	KITCHEN	A		
				FLOOR COVER	6	OTHER	1.00	C	BAS	L	BASE AREA	640	1969	253.65	162,335	BATHS	A		
				INT FINISH	2	DRYWALL	1.00	D	EPA	N	ENCLOSED PORCH	48		122.57	5,883	HEAT/ELEC	A		
				HEATING/COOL	11	HTWT/CL AIR	1.05	F11	O	O	FPL 1S 1OP	1		8,018.90	8,019				
				FUEL SOURCE	1	OIL	1.00												
																		EFF.YR/AGE	1973 / 50
																		COND	30 30 %
																		FUNC	0
																		ECON	0
																		DEPR	30 % GD 70
																		RCNLD	\$324,900