

Key: 4567

Town of BREWSTER - Fiscal Year 2025

9/17/2024 2:15 pm SEQ #: 4.778

LEG
AL
LAND

CURRENT OWNER		PARCEL ID		LOCATION	
VALLE DAVID J & KATHLEEN A 24 BULLRAKE LANE BREWSTER, MA 02631		101-129-0		24 BULLRAKE LANE	
TRANSFER HISTORY		DOS	T	SALE PRICE	BK-PG (Cert)
VALLE DAVID J & KATHLEEN		08/19/1982	XX		3539-181

CLASS	CLASS%	DESCRIPTION		BN ID	BN	CARD	
1010	100	SINGLE FAMILY			1	1 of 1	
PMT NO	PMT DT	TY	DESC	AMOUNT	INSP	BY	1st %
1040	12/08/2015	2	ADD	2,000	03/31/2017	NF	100 100
506	07/07/2015	2	ADD	40,000	03/31/2017	NF	100 100
		12	CYCLICAL NON		02/12/2013	MR	100 100
537	07/25/2012	7	ALTERATIONS	10,500	02/12/2013	MR	100 100
259	05/16/2003	3	OUT BUILDING	1,000			100 100

DE
TA
CH
ED

TOTAL	26,620 SF	ZONING	RM	FRNT	0	ASSESSED	CURRENT	PREVIOUS
Nbhd	NBHD 13	NOTE				LAND	236,600	223,200
St Ind	AVERAGE		BUILDING	390,500	368,900			
Infl	AVERAGE		DETACHED	2,100	2,000			
			OTHER	0	0			
						TOTAL	629,200	594,100

BU
ILD
ING

TY	QUAL	COND	DIM/NOTE	YB	UNITS	ADJ PRICE	RCNLD
SHF	A	1.00	20 0.80 8X15	2003	120	21.39	2,100

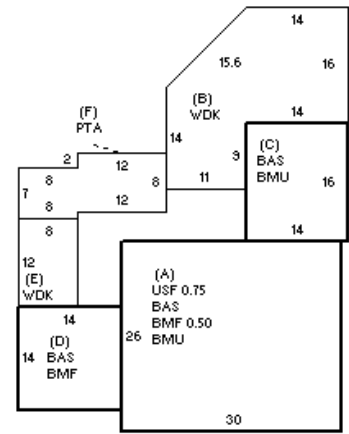

RE
V
IEW

BUILDING	CD	ADJ	DESC	MEASURE	12/3/2020	TCK
MODEL	1		RESIDENTIAL	LIST	2/12/2013	MR
STYLE	4	1.02	CAPE [100%]	REVIEW	2/10/2021	MR
QUALITY	A	1.00	AVG [100%]			
FRAME	1	1.00	WD FRAME [100%]			

BLDG COMMENTS
 ELECTRIC HEAT ON 2ND FLOOR
 BMF=FAM RM/OFFICE/BATH
 INFO @ DOOR (12/3/20)

FIN
G

YEAR BLT	1981	SIZE ADJ	1.000	ELEMENT	CD	DESCRIPTION	ADJ	S	BAT	T	DESCRIPTION	UNITS	YB	ADJ PRICE	RCN	TOTAL RCN	513.839		
NET AREA	1,785	DETAIL ADJ	1.000	FOUNDATION	4	FLR & WALL	1.00	+	BMU	N	BSMT UNFINISHED	1,004		54.77	54,988	CONDITION ELEM	CD		
\$NLA(RCN)	\$288	OVERALL	0.970	EXT COVER	1	WD SHINGLE	1.00	+	BAS	L	BASE AREA	1,004	1981	246.28	247,264	EXTERIOR	A		
				ROOF SHAPE	1	GABLE	1.00	A	USF	L	UPPER STORY FIN	585	1981	180.15	105,390	INTERIOR	A		
				ROOF COVER	1	ASPH/CMP SH	1.00	+	WDK	N	WOOD DECK	535		38.02	20,343	KITCHEN	A		
				FLOOR COVER	1	HARDWOOD	1.00	+	BMF	N	BSMT FINISH	586		39.12	22,927	BATHS	A		
				INT FINISH	5	MIN/OTHER	0.95	D	BAS	L	BASE AREA	196	2015	246.28	48,270	HEAT/ELEC	A		
				HEATING/COOL	2	HOT WATER	1.00	F	PTA	N	PATIO	152		14.65	2,227				
				FUEL SOURCE	2	GAS	1.00		ODS	O	OUTDOOR SHOWER	1		2,342.60	2,343				
																		EFF.YR/AGE	1985 / 38
																		COND	24 24 %
																		FUNC	0
																		ECON	0
																		DEPR	24 % GD 76
																		RCNLD	\$390,500