

Key: 4732

Town of BREWSTER - Fiscal Year 2025

9/17/2024 2:15 pm SEQ #: 4.944

LEGAL

CURRENT OWNER				PARCEL ID				LOCATION			
ENOS KENNETH E & SALLY E (LIFE ESTATE) 273 MILLSTONE ROAD BREWSTER, MA 02631				100-74-0				273 MILLSTONE ROAD			
TRANSFER HISTORY				DOS	T	SALE PRICE		BK-PG (Cert)			
ENOS KENNETH E & SALLY E				04/16/2015	F	1 28805-316					
ENOS KENNETH E & SALLY E				10/17/1974	XX	2110-33					

CLASS	CLASS%	DESCRIPTION			BN ID	BN	CARD	
1010	100	SINGLE FAMILY				1	1 of 1	
PMT NO	PMT DT	TY	DESC	AMOUNT	INSP	BY	1st	%
24-138	02/22/2024	7	ALTERATIONS	5,257				0
712	08/02/2016	77	SOLAR PANELS	18,000	03/31/2017	NF	100	100
		12	CYCLICAL NON		04/01/0513	SF	100	100

LAND

CD	T	AC/SF/UN	Nbhd	St Ind	Infl	ADJ BASE	SAF	Topo	Lpi	VC	CREDIT AMT	ADJ VALUE					
100	S	18,100	13	1.00	A	1.00	A	1.00	197,280	2.40	A	1.00	RM2	0.90			196,990

TOTAL	18,100 SF	ZONING	RM	FRNT	0	ASSESSED	CURRENT	PREVIOUS
Nbhd	NBHD 13	NOTE	LAND	197,000	185,900			
St Ind	AVERAGE		BUILDING	371,600	356,100			
Infl	AVERAGE		DETACHED	0	0			
			OTHER	0	0			
		TOTAL		568,600	542,000			

DETAILED

TY	QUAL	COND	DIM/NOTE	YB	UNITS	ADJ PRICE	RCNLD

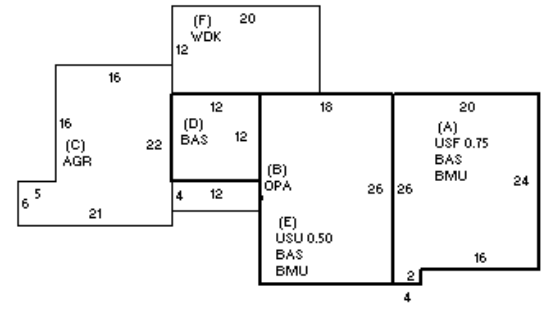

BUILDING

BUILDING	CD	ADJ	DESC	MEASURE	1/6/2021	TCK
MODEL	1		RESIDENTIAL	LIST	1/6/2021	EST
STYLE	4	1.02	CAPE [100%]	REVIEW	2/17/2021	MR
QUALITY	+	1.10	PLUS AVE [100%]			
FRAME	1	1.00	WD FRAME [100%]			

BLDG COMMENTS
27 SOLAR PANELS EST
INFO @ DOOR (1/6/21)

G

YEAR BLT	1974	SIZE ADJ	1.000	ELEMENT	CD	DESCRIPTION	ADJ	S	BAT	T	DESCRIPTION	UNITS	YB	ADJ PRICE	RCN	TOTAL RCN	530,895				
NET AREA	1,466	DETAIL ADJ	1.000	FOUNDATION	4	FLR & WALL	1.00	+	BMU	N	BSMT UNFINISHED	956		66.20	63,285	CONDITION ELEM	CD				
\$NLA(RCN)	\$362	OVERALL	1.020	EXT COVER	1	WD SHINGLE	1.00	A	USF	L	UPPER STORY FIN	366	1974	208.38	76,268	EXTERIOR	A				
				ROOF SHAPE	1	GABLE	1.00	B	OPA	N	OPEN PORCH	48		56.10	2,693	INTERIOR	A				
				ROOF COVER	1	ASPH/CMP SH	1.00	C	AGR	N	ATT GARAGE	382		46.42	17,734	KITCHEN	A				
				FLOOR COVER	1	HARDWOOD	1.00	+	BAS	L	BASE AREA	1,100	1974	293.17	322,484	BATHS	A				
				INT FINISH	2	DRYWALL	1.00	E	USU	N	UPPER STORY UNF	234		63.32	14,816	HEAT/ELEC	A				
				HEATING/COOL	2	HOT WATER	1.00	F	WDK	N	WOOD DECK	240		43.98	10,556						
				FUEL SOURCE	1	OIL	1.00	F21	O	FPL 2S 1OP	1		11,389.40	11,389							
CAPACITY		UNITS	ADJ															EFF.YR/AGE	1974 / 49		
STORIES	1.75		1.00															COND	30 30 %		
ROOMS	5		1.00															FUNC	0		
BEDROOMS	3		1.00															ECON	0		
BATHROOMS	2		1.00															DEPR	30	% GD	70
FIXTURES	8		\$11,669															RCNLD	\$371,600		
GARAGE SPACES	0		1.00																		
% BSMT FIN	0		1.00																		
# 1/2 BATHS	1		1.00																		
# OF UNITS	1		1.00																		