

Key: 4999

Town of BREWSTER - Fiscal Year 2025

9/17/2024 2:15 pm SEQ #: 5.219

LEG
A
L

L
A
N
D

CURRENT OWNER				PARCEL ID				LOCATION				
WILSON GERRIE ANNA (LIFE ESTATE)				125-71-0				105 MAPLE LANE				
105 MAPLE LANE				TRANSFER HISTORY				DOS	T	SALE PRICE	BK-PG (Cert)	
BREWSTER, MA 02631				WILSON GERRIE ANNA (LIFE				09/08/2021	F	1	34449-19	
				WILSON GERRIE ANNA				07/02/2000	DC		11757-76	
				GILARDINO ELSIE V LIFE E				10/13/1998	A	100	11757-76	

CLASS	CLASS%	DESCRIPTION			BN ID	BN	CARD	
1010	100	SINGLE FAMILY				1	1 of 1	
PMT NO	PMT DT	TY	DESC	AMOUNT	INSP	BY	1st	%
240	04/10/2020	77	SOLAR PANELS	9,350	05/13/2022	TCK	100	100
318	04/13/2018	2	ADD	3,500	05/23/2019	NF	100	100
801	09/06/2016	7	ALTERATIONS	12,000	02/17/2017	NF	100	100
54	01/16/2007	2	ADD		09/16/2008	JH	100	100
647	12/11/1998	7	ALTERATIONS	700			100	100

CD	T	AC/SF/UN	Nbhd	St Ind	Infl	ADJ BASE	SAF	Topo	Lpi	VC	CREDIT AMT	ADJ VALUE
100	S	15,170	9	1.00	9-A	1.00	A	1.00				404,110

TOTAL	15,170 SF	ZONING	RM	FRNT	0	ASSESSED	CURRENT	PREVIOUS
Nbhd	NBHD 9	N O T E	VIEW OF OWL POND IN REAR			LAND	404,100	381,300
St Ind	ROBINWOOD		BUILDING	579,600	547,500			
Infl	AVERAGE		DETACHED	0	0			
			OTHER	0	0			
						TOTAL	983,700	928,800

TY	QUAL	COND	DIM/NOTE	YB	UNITS	ADJ PRICE	RCNLD

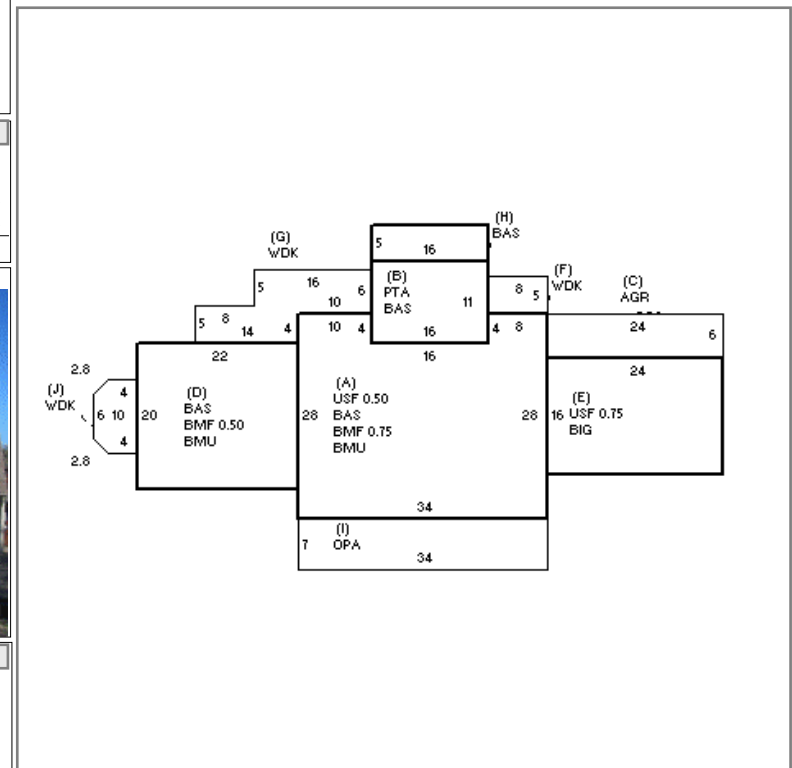

BUILDING	CD	ADJ	DESC	MEASURE	5/23/2019	NF
MODEL	1		RESIDENTIAL	LIST	2/24/2007	JH
STYLE	4	1.02	CAPE [100%]	REVIEW	5/17/2022	JMG
QUALITY	A	1.00	AVG [100%]			
FRAME	1	1.00	WD FRAME [100%]			

BLDG COMMENTS
17 SOLAR PANELS

D
E
T
A
C
H
E
D

B
U
I
L
D
I
N
G

YEAR BLT	1968	SIZE ADJ	1.000	ELEMENT	CD	DESCRIPTION	ADJ	S	BAT	T	DESCRIPTION	UNITS	YB	ADJ PRICE	RCN	TOTAL RCN	715,580	
NET AREA	2,316	DETAIL ADJ	1.000	FOUNDATION	4	FLR & WALL	1.00	+	BMU	N	BSMT UNFINISHED	1,328		55.43	73,605	CONDITION ELEM	CD	
\$NLA(RCN)	\$309	OVERALL	1.020	EXT COVER	1	WD SHINGLE	1.00	+	BMF	N	BSMT FINISH	886		36.31	32,173	EXTERIOR	G	
				ROOF SHAPE	1	GABLE	1.00	+	USF	L	UPPER STORY FIN	732	1968	187.53	137,269	INTERIOR	G	
				ROOF COVER	1	ASPH/CMP SH	1.00	+	BAS	L	BASE AREA	1,144	1968	246.40	281,883	KITCHEN	G	
				FLOOR COVER	2	SOFTWOOD	1.00	B	PTA	N	PATIO	176		15.40	2,711	BATHS	G	
				INT FINISH	2	DRYWALL	1.00	C	AGR	N	ATT GARAGE	144		45.72	6,584	HEAT/ELEC	G	
				HEATING/COOL	2	HOT WATER	1.00	D	BAS	L	BASE AREA	440	2007	246.40	108,417			
				FUEL SOURCE	2	GAS	1.00	E	BIG	N	BUILT-IN GARAGE	384		54.15	20,794			
								+	WDK	N	WOOD DECK	256		39.98	10,236			
								I	OPA	N	OPEN PORCH	238		51.00	12,138			
								F22	O	FPL 2S 2OP	1		12,721.40	12,721				
								GEN	O	GENERATOR	1		0.00					
								ODS	O	OUTDOOR SHOWER	1		2,463.30	2,463				
																EFF_YR/AGE	1995 / 28	
																COND	19 19 %	
																FUNC	0	
																ECON	0	
																DEPR	19 % GD 81	
																RCNLD	\$579,600	