

Key: 5056

Town of BREWSTER - Fiscal Year 2025

9/17/2024 2:15 pm SEQ #: 5.281

LEGAL

LAND

DETACHED

BUILDING

CURRENT OWNER				PARCEL ID				LOCATION			
PERZAN KAZIMIERZ & GRAZYNA 7 CHIPPINS HILL ROAD KENSINGTON, CT 06037				125-104-0				423 HOLLY AVENUE			
TRANSFER HISTORY				DOS	T	SALE PRICE	BK-PG (Cert)				
PERZAN KAZIMIERZ & GRAZYNA				10/27/2020	QS	550,000	33403-332				
LABOSSIERE BRUCE F & MARI				04/25/2008	QS	440,000	22859-246				
DIGIOVANNI LOLA V				05/26/2006	A	1	21035-341				

CLASS	CLASS%	DESCRIPTION			BN ID	BN	CARD	
1010	100	SINGLE FAMILY				1	1 of 1	
PMT NO	PMT DT	TY	DESC	AMOUNT	INSP	BY	1st	%
974	12/09/2022	7	ALTERATIONS	11,000	03/13/2023	TCK	100	100
837	10/27/2020	15	SALE REVIEW	550,000	03/18/2020	JMG	100	100
875	10/20/2017	5	OTHER	1,500	05/08/2018	NF	100	100
382	10/29/2015	7	ALTERATIONS	3,500	04/15/2016	WFF	100	100
	05/07/2013	7	ALTERATIONS	1,500	08/07/2014	RJM	100	100

CD	T	AC/SF/UN	Nbhd	St Ind	Infl	ADJ BASE	SAF	Topo	Lpi	VC	CREDIT AMT	ADJ VALUE
100	S	15,120	9	1.00	9-A	1.00	A	1.00				233,900

TOTAL	15,120 SF	ZONING	RR	FRNT	0	ASSESSED	CURRENT	PREVIOUS
Nbhd	NBHD 9	NOTE	LAND	233,900	220,700			
St Ind	ROBINWOOD		BUILDING	424,800	401,300			
Infl	AVERAGE		DETACHED	0	0			
			OTHER	0	0			
			TOTAL	658,700	622,000			

TY	QUAL	COND	DIM/NOTE	YB	UNITS	ADJ PRICE	RCNLD



BLDG COMMENTS
HATCH TO ATTIC

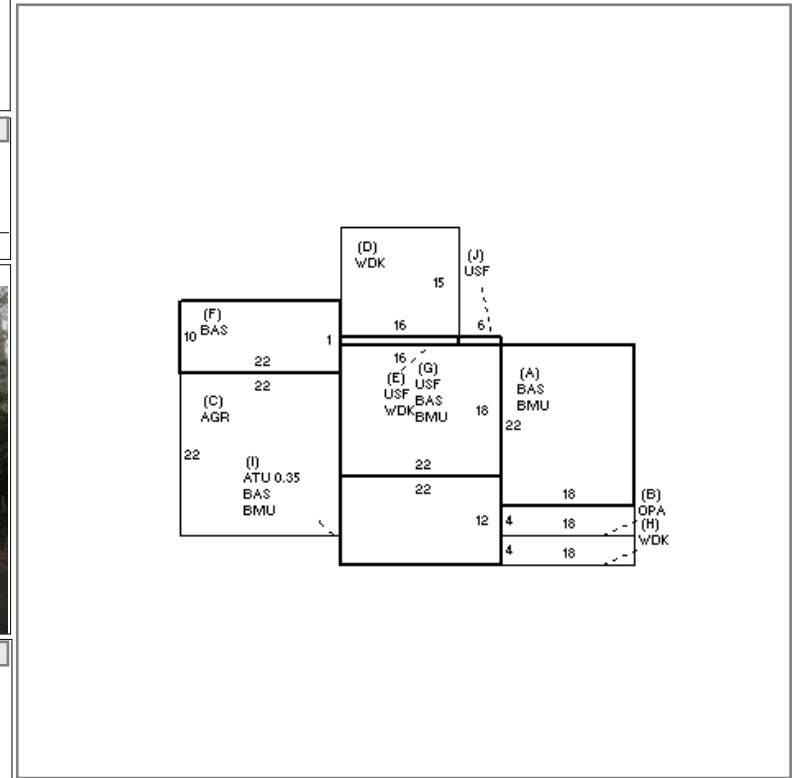

BUILDING	CD	ADJ	DESC	MEASURE	5/21/2019	NF
MODEL	1		RESIDENTIAL	LIST	7/2/2019	NF
STYLE	4	1.02	CAPE [100%]	REVIEW	4/3/2023	EMZ
QUALITY	A	1.00	AVG [100%]			
FRAME	1	1.00	WD FRAME [100%]			

YEAR BLT	1983	SIZE ADJ	1.000	ELEMENT	CD	DESCRIPTION	ADJ	S	BAT	T	DESCRIPTION	UNITS	YB	ADJ PRICE	RCN
NET AREA	1,694	DETAIL ADJ	1.000	FOUNDATION	4	FLR & WALL	1.00	+	BMU	N	BSMT UNFINISHED	1,056		57.59	60,818
\$NLA(RCN)	\$310	OVERALL	1.020	EXT COVER	1	WD SHINGLE	1.00	B	OPA	N	OPEN PORCH	72		51.00	3,672
				ROOF SHAPE	1	GABLE	1.00	C	AGR	N	ATT GARAGE	484		40.45	19,576
				ROOF COVER	1	ASPH/CMP SH	1.00	+	WDK	N	WOOD DECK	328		39.99	13,115
				FLOOR COVER	1	HARDWOOD	1.00	+	BAS	L	BASE AREA	1,276	1983	251.43	320,825
				INT FINISH	2	DRYWALL	1.00	I	ATU	N	ATTIC UNF	92		54.47	5,011
				HEATING/COOL	2	HOT WATER	1.00	+	USF	L	UPPER STORY FIN	418	1983	189.44	79,186
				FUEL SOURCE	1	OIL	1.00		F11	O	FPL 1S 1OP	1		7,789.70	7,790
									ODS	O	OUTDOOR SHOWER	1		2,463.30	2,463

TOTAL RCN	524,389
CONDITION ELEM	CD
EXTERIOR	G
INTERIOR	G
KITCHEN	G
BATHS	A
HEAT/ELEC	A
EFF.YR/AGE	1995 / 28
COND	19 19 %
FUNC	0
ECON	0
DEPR	19 % GD 81
RCNLD	\$424,800