

Key: 5093

Town of BREWSTER - Fiscal Year 2025

9/17/2024 2:15 pm SEQ #: 5.318

LEGAL

LAND

CURRENT OWNER				PARCEL ID				LOCATION			
KELLY PAUL & SHAWN 22 CRANBERRY LANE BREWSTER, MA 02631				137-70-0				22 CRANBERRY LANE			
TRANSFER HISTORY				DOS	T	SALE PRICE	BK-PG (Cert)				
KELLY PAUL & SHAWN				11/08/2019	QS	375,000	32452-145				
LAY RICHARD F & CAROL E				02/14/2011	F	1	25258-34				
LAY RICHARD F & CAROL E				11/22/1999	F	1	12679-038				

CLASS	CLASS%	DESCRIPTION			BN ID	BN	CARD	
1010	100	SINGLE FAMILY				1	1 of 1	
PMT NO	PMT DT	TY	DESC	AMOUNT	INSP	BY	1st	%
23-721	06/14/2023	7	ALTERATIONS	73,572	05/28/2024	TCK	100	100
	11/07/2019	16	MLS REVIEW	375,000	07/15/2020	JMG	100	100
567	06/27/2016	77	SOLAR PANELS	14,000	02/17/2017	NF	100	100
		12	CYCLICAL NON		01/29/2007	NP	100	100
494	10/27/1993	5	OTHER	1,500			100	100

CD	T	AC/SF/UN	Nbhd	St Ind	Infl	ADJ BASE	SAF	Topo	Lpi	VC	CREDIT AMT	ADJ VALUE
100	S	29,100	9	1.00	A	1.00	A	1.00	R07	1.25		302,260
350	A	0.441	9	1.00	A	1.00	A	1.00	TWP	1.00		930

TOTAL	1.109 Acres				ZONING	RM	FRNT	0	ASSESSED	CURRENT	PREVIOUS
Nbhd	NBHD 9				N O T E	Lots 29 & 30 Plan Bk 220 Pg 9 POND VIEW			LAND	303,200	286,000
St Ind	AVERAGE					LAND	343,300	315,600	BUILDING	0	0
Infl	AVERAGE					OTHER	0	0	OTHER	0	0
									TOTAL	646,500	601,600

TY	QUAL	COND	DIM/NOTE	YB	UNITS	ADJ PRICE	RCNLD



BUILDING	CD	ADJ	DESC	MEASURE	6/4/2019	NF
MODEL	1		RESIDENTIAL	LIST	1/29/2007	JH
STYLE	1	1.00	RANCH [100%]	REVIEW	6/11/2024	EMZ
QUALITY	A	1.00	AVG [100%]	14 SOLAR PANELS		
FRAME	1	1.00	WD FRAME [100%]			

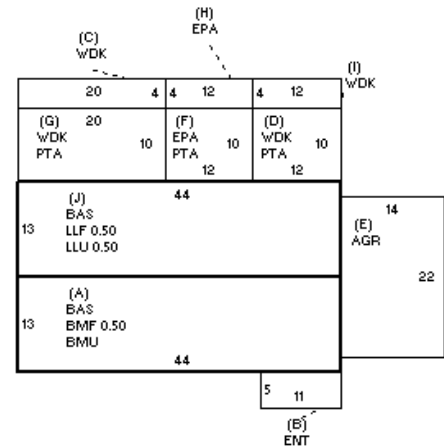

DETACHED

BUILDING

YEAR BLT	1979	SIZE ADJ	1.000
NET AREA	1,430	DETAIL ADJ	1.000
\$NLA(RCN)	\$320	OVERALL	0.950
CAPACITY		UNITS	ADJ
STORIES	1	1.00	
ROOMS	6	1.00	
BEDROOMS	2	1.00	
BATHROOMS	2	1.00	
FIXTURES	8	\$9,880	
GARAGE SPACES	1	1.00	
% BSMT FIN	50	1.00	
# 1/2 BATHS	1	1.00	
# OF UNITS	1	1.00	

ELEMENT	CD	DESCRIPTION	ADJ
FOUNDATION	4	FLR & WALL	1.00
EXT COVER	1	WD SHINGLE	1.00
ROOF SHAPE	1	GABLE	1.00
ROOF COVER	1	ASPH/CMP SH	1.00
FLOOR COVER	1	HARDWOOD	1.00
INT FINISH	2	DRYWALL	1.00
HEATING/COOL	5	ELECTRIC BB	1.00
FUEL SOURCE	3	ELECTRIC	0.95

S	BAT	T	DESCRIPTION	UNITS	YB	ADJ PRICE	RCN
A	BMU	N	BSMT UNFINISHED	572		63.50	36,324
A	BMF	N	BSMT FINISH	286		38.32	10,959
+	BAS	L	BASE AREA	1,144	1979	241.20	275,933
B	ENT	N	ENCLOSED ENTRY	55		110.41	6,072
+	WDK	N	WOOD DECK	448		37.24	16,684
D	PTA	N	PATIO	120		15.11	1,813
E	AGR	N	ATT GARAGE	308		40.13	12,359
F	PTA	N	PATIO	120		15.11	1,813
+	EPA	N	ENCLOSED PORCH	168		72.65	12,206
G	PTA	N	PATIO	200		14.35	2,870
J	LLU	N	LOWER LEVEL UNF	286		87.78	25,105
J	LLF	L	LOWER LEVEL FIN	286	1979	134.41	38,440
F11	O		FPL 1S 1OP	1		7,255.20	7,255

TOTAL RCN	457,712	
CONDITION ELEM	CD	
EXTERIOR	G	
INTERIOR	A	
KITCHEN	A	
BATHS	A	
HEAT/ELEC	A	
EFF.YR/AGE	1983 / 40	
COND	25	25 %
FUNC	0	
ECON	0	
DEPR	25	% GD 75
RCNLD	\$343,300	