

Key: 5128

Town of BREWSTER - Fiscal Year 2025

9/17/2024 2:15 pm SEQ #: 5.353

LEGALS

CURRENT OWNER				PARCEL ID				LOCATION			
CRANIN ANDREW & BONNIE 95 CLIFF POND ROAD BREWSTER, MA 02631				110-5-0				95 CLIFF POND ROAD			
TRANSFER HISTORY				DOS	T	SALE PRICE	BK-PG (Cert)				
CRANIN ANDREW & BONNIE				07/07/2008	QS	355,000	(186405)				
SICKMAN E ELAINE				07/07/2008	DC		(DOC# 1,093,518)				
SICKMAN JOHN E & E ELAINE				04/18/1975	XX	12,500	(64239)				

CLASS	CLASS%	DESCRIPTION		BN ID	BN	CARD	
1010	100	SINGLE FAMILY			1	1 of 1	
PMT NO	PMT DT	TY	DESC	AMOUNT	INSP	BY	1st %
380	05/08/2012	5	OTHER	14,370	02/12/2013	MR	100 100
226	04/04/2012	2	ADD	17,000	02/12/2013	MR	100 100
354	07/06/2011	7	ALTERATIONS	15,000	03/07/2012	MR	100 100
638	12/09/2010	7	ALTERATIONS	10,000	03/07/2012	MR	100 100

LAND

CD	T	AC/SF/UN	Nbhd	St Ind	Infl	ADJ BASE	SAF	Topo	Lpi	VC	CREDIT AMT	ADJ VALUE				
100	S	15,150	13	1.00	13G	1.00	A	1.00	252,080	2.79	A	1.00	R04	1.15		244,570

DETACHED

TOTAL	15,150 SF	ZONING	RL	FRNT	0	ASSESSED	CURRENT	PREVIOUS
Nbhd	NBHD 13	NOTE				LAND	244,600	230,700
St Ind	CLIFF POND		LAND	415,300	397,000			
Infl	AVERAGE		BUILDING	3,300	3,300			
			OTHER	0	0			
						TOTAL	663,200	631,000

TY	QUAL	COND	DIM/NOTE	YB	UNITS	ADJ PRICE	RCNLD	PHOTO	11/20/2020
SHF	G	1.20	10 0.90	12X12		144	25.67	3,300	

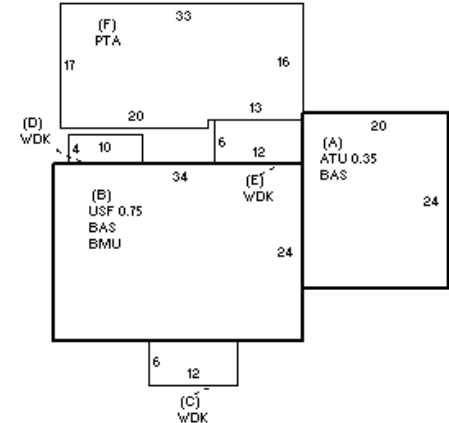

BUILDING

BUILDING	CD	ADJ	DESC	MEASURE	11/20/2020	TCK
MODEL	1		RESIDENTIAL	LIST	11/20/2020	EST
STYLE	4	1.02	CAPE [100%]	REVIEW	2/4/2021	MR
QUALITY	A	1.00	AVG [100%]			
FRAME	1	1.00	WD FRAME [100%]			

BLDG COMMENTS

G

YEAR BLT	1985	SIZE ADJ	1.000	ELEMENT	CD	DESCRIPTION	ADJ	S	BAT	T	DESCRIPTION	UNITS	YB	ADJ PRICE	RCN	TOTAL RCN	512,744
NET AREA	1,908	DETAIL ADJ	1.000	FOUNDATION	4	FLR & WALL	1.00	A	BAS	L	BASE AREA	480	2012	241.57	115,954		
\$NLA(RCN)	\$269	OVERALL	0.980	EXT COVER	1	WD SHINGLE	1.00	A	ATU	N	ATTIC UNF	168		52.33	8,792		
				ROOF SHAPE	1	GABLE	1.00	B	BMU	N	BSMT UNFINISHED	816		57.82	47,181		
				ROOF COVER	1	ASPH/CMP SH	1.00	B	BAS	L	BASE AREA	816	1985	241.57	197,121		
				FLOOR COVER	1	HARDWOOD	1.00	B	USF	L	UPPER STORY FIN	612	1985	180.17	110,265		
				INT FINISH	2	DRYWALL	1.00	+	WDK	N	WOOD DECK	184		38.42	7,069		
				HEATING/COOL	14	ELECT BB+AC	1.01	F	PTA	N	PATIO	548		11.69	6,404		
				FUEL SOURCE	3	ELECTRIC	0.95		F21	O	FPL 2S 10P	1		9,948.00	9,948		
									ODS	O	OUTDOOR SHOWER	1		2,366.70	2,367		

CONDITION ELEM	CD
EXTERIOR	G
INTERIOR	A
KITCHEN	A
BATHS	A
HEAT/ELEC	A

EFF.YR/AGE	1995 / 28
COND	19 19 %
FUNC	0
ECON	0
DEPR	19 % GD 81
RCNLD	\$415,300