

Key: 518

Town of BREWSTER - Fiscal Year 2025

9/17/2024 2:15 pm SEQ #: 535

LEGAL

CURRENT OWNER				PARCEL ID				LOCATION			
PLANSKY MADELINE C 70 OLD NAHANT ROAD WAKEFIELD, MA 01880				68-8-0				17 BARBERRY LANE			
TRANSFER HISTORY				DOS	T	SALE PRICE	BK-PG (Cert)				
PLANSKY MADELINE C				01/17/1991	A	100	(122522)				

CLASS	CLASS%	DESCRIPTION			BN ID	BN	CARD	
1010	100	SINGLE FAMILY				1	1 of 1	
PMT NO	PMT DT	TY	DESC	AMOUNT	INSP	BY	1st	%
508	05/31/2019	7	ALTERATIONS	48,000	07/09/2020	NF	100	100
286	03/29/2019	7	ALTERATIONS	16,700	07/09/2020	NF	100	100
259	03/25/2019	7	ALTERATIONS	8,500	07/09/2020	NF	100	100
73	01/27/2017	5	OTHER	4,900	04/17/2018	NF	100	100
395	06/30/2000	7	ALTERATIONS	15,000	05/01/2001	SJM	100	100

LAND

CD	T	AC/SF/UN	Nbhd	St Ind	Infl	ADJ BASE	SAF	Topo	Lpi	VC	CREDIT AMT	ADJ VALUE	
100	S	31,363 4	1.00	4-B	1.00	A	1.00	1,468,640	1.56	A	1.00	BVG 6.70	1,651,790

TOTAL	31,363 SF	ZONING	RM	FRNT	0	ASSESSED	CURRENT	PREVIOUS
Nbhd	NBHD 4	NOTE				LAND	1,651,800	1,558,400
St Ind	KINGS GRANT		BUILDING	913,100	873,600			
Infl	AVERAGE		DETACHED	0	0			
			OTHER	0	0			
						TOTAL	2,564,900	2,432,000

DETACHED

TY	QUAL	COND	DIM/NOTE	YB	UNITS	ADJ PRICE	RCNLD	PHOTO	10/15/2020
									10/15/2020

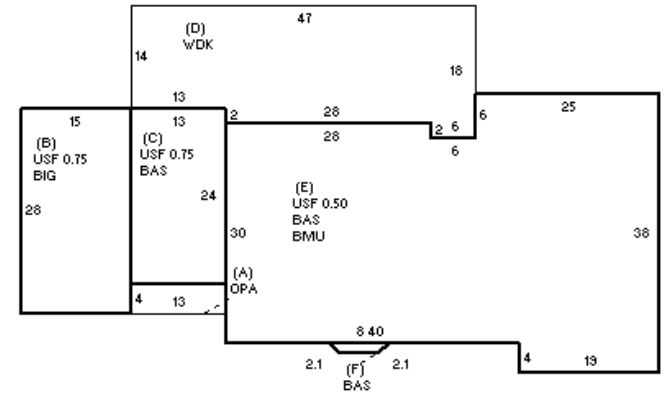

BUILDING

BUILDING	CD	ADJ	DESC	MEASURE	10/15/2020	NF
MODEL	1		RESIDENTIAL	LIST	10/15/2020	EST
STYLE	4	1.02	CAPE [100%]	REVIEW	1/15/2020	MR
QUALITY	G	1.30	GOOD [100%]			
FRAME	1	1.00	WD FRAME [100%]			

BLDG COMMENTS		

G

YEAR BLT	1976	SIZE ADJ	0.970	ELEMENT	CD	DESCRIPTION	ADJ	S	BAT	T	DESCRIPTION	UNITS	YB	ADJ PRICE	RCN	TOTAL RCN	1,217,449		
NET AREA	3,772	DETAIL ADJ	1.000	FOUNDATION	4	FLR & WALL	1.00	A	OPA	N	OPEN PORCH	52		66.20	3,443	CONDITION ELEM	CD		
\$NLA(RCN)	\$323	OVERALL	1.050	EXT COVER	1	WD SHINGLE	1.00	B	BIG	N	BUILT-IN GARAGE	420		68.83	28,907	EXTERIOR	G		
				ROOF SHAPE	1	GABLE	1.00	+	USF	L	UPPER STORY FIN	1,516	1976	213.62	323,843	INTERIOR	G		
				ROOF COVER	1	ASPH/CMP SH	1.00	+	BAS	L	BASE AREA	2,256	1976	293.74	662,679	KITCHEN	A		
				FLOOR COVER	3	W/W CARPET	1.00	D	WDK	N	WOOD DECK	738		51.90	38,305	BATHS	A		
				INT FINISH	2	DRYWALL	1.00	E	BMU	N	BSMT UNFINISHED	1,934		66.01	127,665	HEAT/ELEC	A		
				HEATING/COOL	9	WARM/CL AIR	1.03	F21	O	O	FPL 2S 1OP	1		13,440.40	13,440				
				FUEL SOURCE	1	OIL	1.00	ODS	O	O	OUTDOOR SHOWER	1		3,197.60	3,198				
																		EFF.YR/AGE	1983 / 40
																		COND	25 25 %
																		FUNC	0
																		ECON	0
																		DEPR	25 % GD 75
																		RCNLD	\$913,100