

Key: 529

Town of BREWSTER - Fiscal Year 2025

9/17/2024 2:15 pm SEQ #: 546

LEGALS

LAND

DETACHED

BUILDING

CURRENT OWNER				PARCEL ID				LOCATION			
BOWMAN MARK S & MICKI L 42 BARBERRY LANE BREWSTER, MA 02631				68-13-0				42 BARBERRY LANE			
TRANSFER HISTORY				DOS	T	SALE PRICE	BK-PG (Cert)				
BOWMAN MARK S & MICKI L				09/21/2015	O	1,090,000	(207439)				
LICHTY SUSAN CAREY & D TE				07/17/1998	QS	329,000	(149392)				
KIM SUNJA Y				09/02/1997	QS	305,000	N/A-N/A				

CLASS	CLASS%	DESCRIPTION			BN ID	BN	CARD	
1010	100	SINGLE FAMILY				1	1 of 1	
PMT NO	PMT DT	TY	DESC	AMOUNT	INSP	BY	1st	%
699	08/13/2018	7	OWNER REQUES	30,000	07/10/2023	JMG	100	100
454	05/24/2018	7	ALTERATIONS	15,000	05/15/2018	NF	100	100
1096	11/22/2016	1	NEW CONSTRUCT	975,000	04/17/2018	NF	100	100
943	10/14/2016	6	DEMO	25,000	02/02/2017	NF	100	100

TOTAL	26,517 SF	ZONING	RM	FRNT	0	ASSESSED	CURRENT	PREVIOUS
Nbhd	NBHD 4	N O P O N D V I E W				LAND	1,229,300	1,159,700
St Ind	KINGS GRANT		BUILDING	1,652,300	1,560,600			
Infl	AVERAGE		DETACHED	0	0			
				OTHER	0	0		
				TOTAL	2,881,600	2,720,300		

TY	QUAL	COND	DIM/NOTE	YB	UNITS	ADJ PRICE	RCNLD



BLDG COMMENTS
LLF = BDRM, BTH, 2 REC RMS; 4 Extra Fixtures + 1 bath has 4 Fixtures

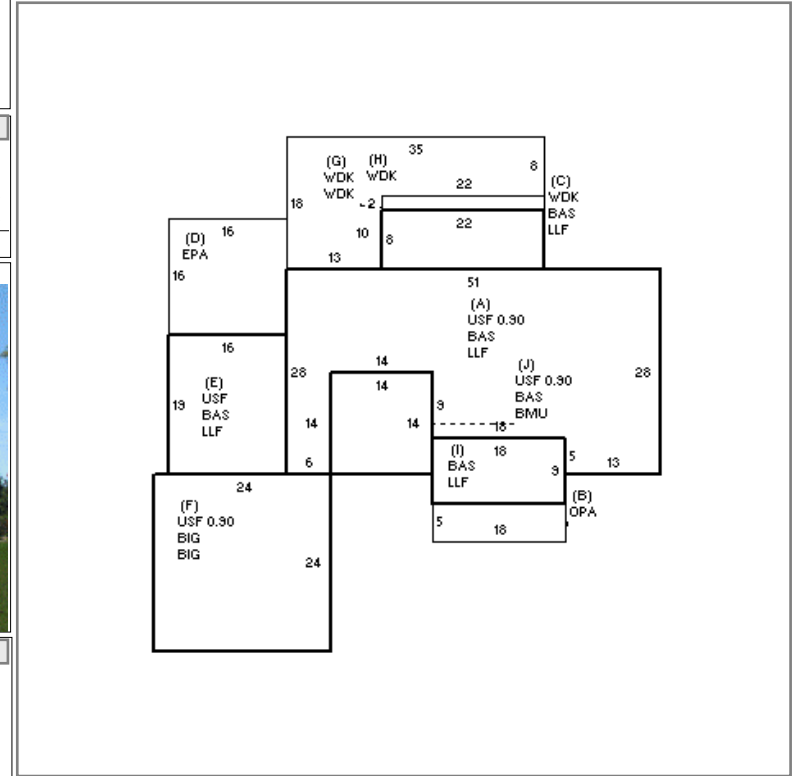

BUILDING	CD	ADJ	DESC	MEASURE	7/10/2023	JMG
MODEL	1		RESIDENTIAL	LIST	7/10/2023	JMG
STYLE	5	1.05	COLONIAL [100%]	REVIEW	7/11/2023	JMG
QUALITY	V	1.65	VERY GOOD [100%]			
FRAME	1	1.00	WD FRAME [100%]			

YEAR BLT	1980	SIZE ADJ	0.970
NET AREA	5,791	DETAIL ADJ	1.000
\$NLA(RCN)	\$328	OVERALL	1.080
CAPACITY		UNITS	ADJ
STORIES	1.9	1.00	
ROOMS	8	1.00	
BEDROOMS	5	1.00	
BATHROOMS	4	1.00	
FIXTURES	17	\$39,382	
GARAGE SPACES	3	1.00	
% BSMT FIN	90	1.00	
# 1/2 BATHS	1	1.00	
# OF UNITS	1	1.00	

ELEMENT	CD	DESCRIPTION	ADJ
FOUNDATION	4	FLR & WALL	1.00
EXT COVER	1	WD SHINGLE	1.00
ROOF SHAPE	3	GAMBREL	1.00
ROOF COVER	1	ASPH/CMP SH	1.00
FLOOR COVER	1	HARDWOOD	1.00
INT FINISH	2	DRYWALL	1.00
HEATING/COOL	9	WARM/CL AIR	1.03
FUEL SOURCE	2	GAS	1.00

S	BAT	T	DESCRIPTION	UNITS	YB	ADJ PRICE	RCN
+	LLF	L	LOWER LEVEL FIN	1,608	1980	199.72	321,149
+	BAS	L	BASE AREA	1,818	2018	392.00	712,653
+	USF	L	UPPER STORY FIN	2,027	2018	252.93	512,697
B	OPA	N	OPEN PORCH	90		86.43	7,778
C	LLF	L	LOWER LEVEL FIN	176	2018	199.72	35,150
D	EPA	N	ENCLOSED PORCH	256		125.23	32,059
F	BIG	N	BUILT-IN GARAGE	576		84.12	48,451
F	BIG	N	BUILT-IN GARAGE	576		84.12	48,451
+	WDK	N	WOOD DECK	674		67.76	45,670
I	BAS	L	BASE AREA	162	2018	391.99	63,503
J	BMU	N	BSMT UNFINISHED	196		115.55	22,647
GFP	O	GAS	FIREPLACE	1		5,403.40	5,403
ODS	O	OUTDOOR	SHOWER	1		4,174.40	4,174

TOTAL RCN	1,899,169	
CONDITION ELEM	CD	
EXTERIOR	A	
INTERIOR	A	
KITCHEN	A	
BATHS	A	
HEAT/ELEC	A	
EFF.YR/AGE	2007 / 16	
COND	13	13 %
FUNC	0	
ECON	0	
DEPR	13	% GD 87
RCNLD	\$1,652,300	