

Key: 5513

Town of BREWSTER - Fiscal Year 2025

9/17/2024 2:15 pm SEQ #: 5.727

LEGALS LAND

Table with columns: CURRENT OWNER, PARCEL ID, LOCATION, TRANSFER HISTORY, DOS, T, SALE PRICE, BK-PG (Cert). Includes owner name: PETTENGILL JEAN ALICE and address: 888 LONG POND ROAD, BREWSTER, MA 02631.

Table with columns: CLASS, CLASS%, DESCRIPTION, BN ID, BN, CARD. Includes details for solar panels and alterations with dates and amounts.

Table with columns: TOTAL, ZONING, RM, FRNT, ADJ BASE, SAF, Topo, Lpi, VC, CREDIT AMT, ADJ VALUE. Includes assessed and current values for land and building.

Table with columns: TY, QUAL, COND, DIM/NOTE, YB, UNITS, ADJ PRICE, RCNLD. Includes property characteristics like SHF, DGF, HTB, BBN.

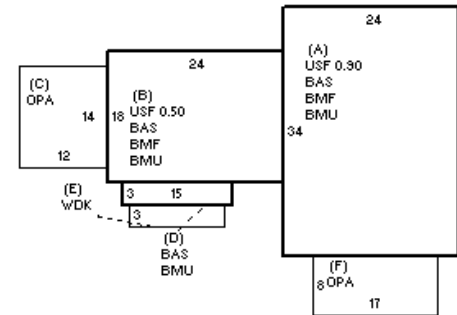

Table with columns: BUILDING, CD, ADJ, DESC, MEASURE, 2/26/2021, TCK. Includes building details like MODEL, STYLE, QUALITY, FRAME.

BLDG COMMENTS: BMF=2 STUDIOS/BATH, 19 SOLAR PANELS, INFO @ DOOR (2/26/2021)

DETAILED

BUILDING

Large table with columns: YEAR BLT, NET AREA, \$NLA(RCN), CAPACITY, UNITS, ADJ, ELEMENT, CD, DESCRIPTION, ADJ, S, BAT, T, DESCRIPTION, UNITS, YB, ADJ PRICE, RCN, TOTAL RCN, 872.709, CONDITION ELEM, CD, EFF.YR/AGE, 2009 / 14, COND, FUNC, ECON, DEPR, RCNLD, \$768,000.