

Key: 5676

Town of BREWSTER - Fiscal Year 2025

9/17/2024 2:15 pm SEQ #: 5.894

LEGAL

CURRENT OWNER				PARCEL ID				LOCATION			
STICKLE ROBERT LEWIS SR TRUSTEE STICKLE FAMILY LIVING TRUST 121 SHEEP POND DRIVE BREWSTER, MA 02631				74-31-0				121 SHEEP POND DRIVE			
TRANSFER HISTORY				DOS	T	SALE PRICE	BK-PG (Cert)				
STICKLE ROBERT LEWIS SR T				08/25/2000	D	269,500	13202-327				
GUALTIERI SHARON B				12/16/1996	QS	41,000	10526-167				

CLASS	CLASS%	DESCRIPTION			BN ID	BN	CARD	
1010	100	SINGLE FAMILY				1	1 of 1	
PMT NO	PMT DT	TY	DESC	AMOUNT	INSP	BY	1st	%
1007	12/02/2022	7	ALTERATIONS	15,000	03/01/2023	TCK	100	100
743	11/07/2007	12	CYCLICAL NON	30,000	11/09/2011	MR	100	100
		2	ADD		09/23/2008	JH	100	100
157	03/28/2003	12	CYCLICAL NON	38,000	11/19/2003	JB	100	100
		2	ADD		06/08/2004	WH	100	100

LAND

CD	T	AC/SF/UN	Nbhd	St Ind	Infl	ADJ BASE	SAF	Topo	Lpi	VC	CREDIT AMT	ADJ VALUE
100	S	15,681	15	1.00	15A	1.00	A	1.00			328,800	320,650

TOTAL	15,681 SF	ZONING	RM	FRNT	0	ASSESSED	CURRENT	PREVIOUS
Nbhd	NBHD 15	NOTE				LAND	320,700	302,500
St Ind	SHEEP POND EST.		BUILDING	547,500	523,100			
Infl	AVERAGE		DETACHED	0	0			
			OTHER	0	0			
						TOTAL	868,200	825,600

DETAILED

TY	QUAL	COND	DIM/NOTE	YB	UNITS	ADJ PRICE	RCNLD

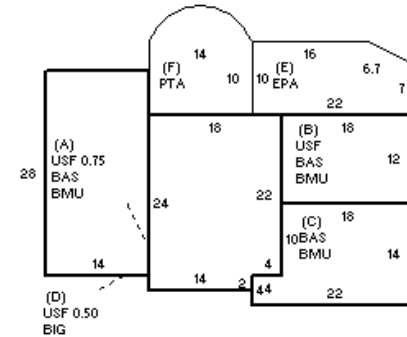

BUILDING

BUILDING	CD	ADJ	DESC	MEASURE	3/2/2021	NF
MODEL	1		RESIDENTIAL	LIST	11/9/2011	MR
STYLE	4	1.02	CAPE [100%]	REVIEW	3/29/2023	EMZ
QUALITY	A+	1.20	AVG + [100%]			
FRAME	1	1.00	WD FRAME [100%]			

BLDG COMMENTS

INDING

YEAR BLT	2000	SIZE ADJ	1.000	ELEMENT	CD	DESCRIPTION	ADJ	S	BAT	T	DESCRIPTION	UNITS	YB	ADJ PRICE	RCN	TOTAL RCN	629,362			
NET AREA	1,638	DETAIL ADJ	1.000	FOUNDATION	4	FLR & WALL	1.00	+	BMU	N	BSMT UNFINISHED	908		75.76	68,786	CONDITION ELEM	CD			
\$NLA(RCN)	\$384	OVERALL	1.070	EXT COVER	1	WD SHINGLE	1.00	+	BAS	L	BASE AREA	908	2000	341.83	310,379	EXTERIOR	A			
				ROOF SHAPE	1	GABLE	1.00	+	USF	L	UPPER STORY FIN	730	2000	236.06	172,324	INTERIOR	A			
				ROOF COVER	1	ASPH/CMP SH	1.00	D	BIG	N	BUILT-IN GARAGE	392		68.16	26,720	KITCHEN	A			
				FLOOR COVER	1	HARDWOOD	1.00	E	EPA	N	ENCLOSED PORCH	211		93.03	19,629	BATHS	G			
				INT FINISH	2	DRYWALL	1.00	F	PTA	N	PATIO	191		19.39	3,704	HEAT/ELEC	G			
				HEATING/COOL	11	HTWT/CL AIR	1.05	F21	O	O	FPL 2S 1OP	1		13,033.90	13,034					
				FUEL SOURCE	1	OIL	1.00	ODS	O	O	OUTDOOR SHOWER	1		3,100.90	3,101					
																		EFF.YR/AGE	2007 / 16	
																		COND	13 13 %	
																		FUNC	0	
																		ECON	0	
																		DEPR	13 % GD 87	
																		RCNLD	\$547,500	