

Key: 5755

Town of BREWSTER - Fiscal Year 2025

9/17/2024 2:15 pm SEQ #: 5.974

LEGAL

CURRENT OWNER		PARCEL ID	LOCATION			
HEMENWAY ELEANOR B TRUSTEE ELEANOR B HEMENWAY TRUST 8513 SEDGEMOOR DRIVE RICHMOND, VA 23228		55-26-0	309 TUBMAN ROAD			
TRANSFER HISTORY		DOS	T	SALE PRICE	BK-PG (Cert)	
HEMENWAY ELEANOR B TRUSTE		05/09/2016	A	136,250	29636-150	
HEMENWAY ELEANOR B TRSTE		04/19/2006	F	100	20923-170	
HEMENWAY ELEANOR B ETAL &		05/20/1998	J	100	11440-186	

CLASS	CLASS%	DESCRIPTION			BN ID	BN	CARD	
1010	100	SINGLE FAMILY				1	1 of 1	
PMT NO	PMT DT	TY	DESC	AMOUNT	INSP	BY	1st	%
77	02/09/2016	7	ALTERATIONS	10,000	03/23/2017	NF	100	100
895	10/21/2013	7	ALTERATIONS	5,850	08/14/2014	RJM	100	100
82	03/02/2004	7	ALTERATIONS	6,000			100	100

LAND

CD	T	AC/SF/UN	Nbhd	St Ind	Infl	ADJ BASE	SAF	Topo	Lpi	VC	CREDIT AMT	ADJ VALUE
100	S	18,500	12 1.00	A 1.00	A 1.00	219,200	2.36	A 1.00	RM3	1.00		219,810

TOTAL	18,500 SF	ZONING	RM	FRNT	0	ASSESSED	CURRENT	PREVIOUS
Nbhd	NBHD 12	NOTE				LAND	219,800	207,400
St Ind	AVERAGE		BUILDING	275,000	259,600			
Infl	AVERAGE		DETACHED	0	0			
			OTHER	0	0			
						TOTAL	494,800	467,000

DETACHED

TY	QUAL	COND	DIM/NOTE	YB	UNITS	ADJ PRICE	RCNLD

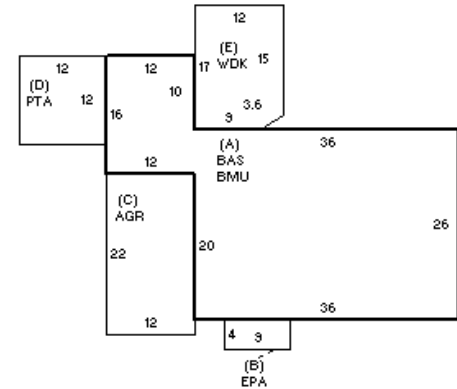

BUILDING

BUILDING	CD	ADJ	DESC	MEASURE	3/29/2019	NF
MODEL	1		RESIDENTIAL	LIST	8/8/2019	NF
STYLE	1	1.00	RANCH [100%]	REVIEW	1/8/2020	MR
QUALITY	A	1.00	AVG [100%]			
FRAME	1	1.00	WD FRAME [100%]			

BLDG COMMENTS
PULL DOWN STAIRS TO ATTIC

G

YEAR BLT	1963	SIZE ADJ	1.000	ELEMENT	CD	DESCRIPTION	ADJ	S	BAT	T	DESCRIPTION	UNITS	YB	ADJ PRICE	RCN	TOTAL RCN	387,370
NET AREA	1,128	DETAIL ADJ	1.000	FOUNDATION	4	FLR & WALL	1.00	A	BMU	N	BSMT UNFINISHED	1,128		56.46	63,690		
\$NLA(RCN)	\$343	OVERALL	1.000	EXT COVER	1	WD SHINGLE	1.00	A	BAS	L	BASE AREA	1,128	1963	253.90	286,394		
				ROOF SHAPE	1	GABLE	1.00	B	EPA	N	ENCLOSED PORCH	36		116.72	4,202		
				ROOF COVER	1	ASPH/CMP SH	1.00	C	AGR	N	ATT GARAGE	264		43.10	11,378		
				FLOOR COVER	1	HARDWOOD	1.00	D	PTA	N	PATIO	144		15.90	2,290		
				INT FINISH	2	DRYWALL	1.00	E	WDK	N	WOOD DECK	201		39.20	7,879		
				HEATING/COOL	1	FORCED AIR	1.00	F11	O	O	FPL 1S 1OP	1		7,637.00	7,637		
				FUEL SOURCE	1	OIL	1.00										
																CONDITION ELEM	CD
																EXTERIOR	V
																INTERIOR	G
																KITCHEN	A
																BATHS	A
																HEAT/ELEC	A
																EFF.YR/AGE	1975 / 48
																COND	29 29 %
																FUNC	0
																ECON	0
																DEPR	29 % GD 71
																RCNLD	\$275,000