

Key: 5856

Town of BREWSTER - Fiscal Year 2025

9/17/2024 2:15 pm SEQ #: 6.081

LEGAL

CURRENT OWNER		PARCEL ID		LOCATION	
BATES DAVID C & CHRISTINE H 217 RUN HILL ROAD BREWSTER, MA 02631		46-4-0		217 RUN HILL ROAD	
TRANSFER HISTORY		DOS	T	SALE PRICE	BK-PG (Cert)
BATES DAVID C & CHRISTINE		08/18/2016	QS	450,000	29869-283
HAMLYN MARK		04/04/2000	O	62,500	12925-148
MCKEON BEVERLY A & TRAVER		12/21/1940	XX	574-26	

CLASS	CLASS%	DESCRIPTION		BN ID	BN	CARD	
1010	100	SINGLE FAMILY			1	1 of 1	
PMT NO	PMT DT	TY	DESC	AMOUNT	INSP	BY	1st %
37	01/18/2001	5	OTHER	8,600	06/19/2001	LB	100 100
626	10/26/2000	7	ALTERATIONS	1,000	06/19/2001	LB	100 100
342	06/05/2000	1	NEW CONSTRUC	180,000	06/19/2001	LB	100 100
343	06/05/2000	3	OUT BUILDING	20,000	06/19/2001	LB	100 100

LAND

CD	T	AC/SF/UN	Nbhd	St Ind	Infl	ADJ BASE	SAF	Topo	Lpi	VC	CREDIT AMT	ADJ VALUE	
100	S	60,000	12	1.00	12N	1.00	A	1.00	219,200	1.00	A	1.00	303,350
300	A	0.348	12	1.00	12N	1.00	A	1.00	12,000	1.00	A	1.00	4,180

TOTAL	1.725 Acres	ZONING	RR	FRNT	0	ASSESSED	CURRENT	PREVIOUS
Nbhd	NBHD 12	N O T E	LAND SIZE CHANGED F/Y 2001 PER PLAN 454 PAGE 72			LAND	307,500	290,100
St Ind	MILL POND		BUILDING	418,300	394,800			
Infl	AVERAGE		DETACHED	34,200	34,000			
			OTHER	0	0			
						TOTAL	760,000	718,900

DETACHED

TY	QUAL	COND	DIM/NOTE	YB	UNITS	ADJ PRICE	RCNLD
GFU	A	1.00	10 0.90	32X24	2001	768 44.90	31,000
HTB	A	1.00	20 0.80			1 4,058.10	3,200

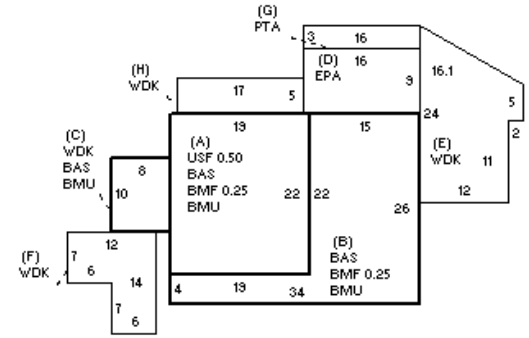

BUILDING	CD	ADJ	DESC	MEASURE	3/27/2018	NF
MODEL	1		RESIDENTIAL	LIST	3/27/2018	EST
STYLE	4	1.02	CAPE [100%]	REVIEW	12/20/2019	MR
QUALITY	A+	1.20	AVG + [100%]			
FRAME	1	1.00	WD FRAME [100%]			

BUILDING

YEAR BLT	2001	SIZE ADJ	1.000	ELEMENT	CD	DESCRIPTION	ADJ	S	BAT	T	DESCRIPTION	UNITS	YB	ADJ PRICE	RCN	TOTAL RCN	497,928
NET AREA	1,173	DETAIL ADJ	1.000	FOUNDATION	4	FLR & WALL	1.00	+	BMU	N	BSMT UNFINISHED	964		72.22	69,616	CONDITION ELEM	CD
\$NLA(RCN)	\$424	OVERALL	1.020	EXT COVER	1	WD SHINGLE	1.00	+	BMF	N	BSMT FINISH	221		49.37	10,911	EXTERIOR	A
				ROOF SHAPE	1	GABLE	1.00	+	BAS	L	BASE AREA	964	2001	325.85	314,123	INTERIOR	A
				ROOF COVER	1	ASPH/CMP SH	1.00	A	USF	L	UPPER STORY FIN	209	2001	227.32	47,511	KITCHEN	A
				FLOOR COVER	1	HARDWOOD	1.00	D	EPA	N	ENCLOSED PORCH	144		98.53	14,189	BATHS	A
				INT FINISH	2	DRYWALL	1.00	+	WDK	N	WOOD DECK	549		47.98	26,342	HEAT/ELEC	A
				HEATING/COOL	2	HOT WATER	1.00	G	PTA	N	PATIO	48		28.23	1,355		
				FUEL SOURCE	2	GAS	1.00	MST	O	MAS/METAL STACK	1		6,153.00	6,153			
								ODS	O	OUTDOOR SHOWER	1		2,956.00	2,956			
				EFF.YR/AGE 2001 / 22													
				COND 16 16 %													
				FUNC 0													
				ECON 0													
				DEPR 16 % GD 84													
				RCNLD \$418,300													